

## VHD Nut Series

The VHD Series anti-backlash assembly provides the maximum load carrying capability and the highest axial and radial stiffness of any Kerk® nut assembly. Designed for smooth, quiet operation and long life, the VHD assembly provides low drag torque by making use of the patented Kerk AXIAL TAKE-UP MECHANISM (see Lead-screw Assemblies: Anti-Backlash Technologies section). Drag and wear associated with high pre-load forces are eliminated with the VHD Series. Screws are 303 stainless steel with Kerk's custom Kerkote® TFE extended life coating optional. Assemblies are available cut-to-length or with screws machined to your requirements.

VHD Series Nut Assemblies



VHD Series Nut

### Technical Data

Material	Polyacetal, Lubricant Additive
Tensile Strength	9,700 psi
Coefficient of Expansion	6.0 x 10 <sup>-5</sup> in/in/°F
Coefficient of Friction Polyacetal Nut to Screw	Static = .08 .08 ** Dynamic = .15 .09 **
Standard Operating Temperature Range	32 - 200° F* (0 - 93° C)*

\* Very high or low temperatures may cause significant changes in the nut fit or drag torque. Please call the HKP Engineering Team at 603 213 6290 for optional temperature range materials.

\*\* with Kerkote® TFE Coating.

### Grease Compatibility

Coatings	Compatible
Kerkote® TFE Coating	YES
Black Ice® TFE Coating	YES
Grease	NO

### Anti-Backlash Life

Without Kerkote® TFE Coating inch / (cm)	With Kerkote® TFE Coating inch / (cm)
200 to 225 million (500 to 570 million)	300 to 350 million (760 to 880 million)

Anti-backlash life is defined as the nut's ability to compensate for wear while maintaining its zero backlash properties. Above life data is based on 25% of the dynamic load rating. Life will vary with loading, operating environment, and duty cycle. The longer screw leads generally provide longer life.

### Identifying the VHD Series Nut Part Number Codes when Ordering

VHD	F	S	R	062	0125	XXXX
Prefix	Nut Mounting Style	Lubrication	Thread Direction	Diameter Code	Nominal Thread Lead Code	Unique Identifier
VHD	F = Flanged (Round) T = Threaded X = Custom	S = Uncoated K = Kerkote® TFE Coating N = Nut only B = Black Ice® TFE Coating	R = Right hand L = Left hand (Not Available for Micro Series)  (Refer to leadscrew charts for availability)	050 = .500 in (13 mm) 062 = .625 in (16 mm) 075 = .750 in (19 mm) 087 = .875 in (22 mm)	(Refer to LEAD CODE Specifications charts, pages 3 to 4)	Proprietary suffix assigned to a specific customer application. The identifier can apply to either a standard or custom part.

NOTE: Dashes must be included in Part Number (-) as shown above. For assistance call our Engineering Team at 603 213 6290.

■ Dimensional Drawings

VHD Flange Mount

VHDF Flange Mount	Screw Diam. A	Nut Diam. B	Nut Length C	Flange Diam. D	Flange Thickness E	Mounting Hole Diam. F	Bolt Circle Diam. G	Hub Width H	Hub Diam. J	Dynamic Load lbs (Kg)	Drag Torque oz-in (N-m)
	inch (mm)	inch (mm)	inch (mm)	inch (mm)	inch (mm)	inch (mm)	inch (mm)	inch (mm)	inch (mm)		
	1/2 (13)	1.12 (28.5)	2.3 (59)	1.75 (44.5)	.23 (5.9)	.22 (5.60)	1.406 (35.71)	.12 (3.1)	.93 (23.62)	150 (68)	2-6 (.014-.02)
	5/8 (16)	1.38 (35.1)	2.6 (66)	2.08 (53)	.28 (7.1)	.22 (5.60)	1.750 (44.45)	N/A	N/A	250 (113)	2-6 (.014-.02)
	3/4 (19)	1.62 (41.2)	2.8 (71)	2.38 (60.5)	.31 (7.9)	.22 (5.60)	2.000 (50.80)	N/A	N/A	350 (159)	3-7 (.02-.05)
	7/8 (22)	1.62 (41.2)	2.8 (71)	2.38 (60.5)	.31 (7.9)	.22 (5.60)	2.000 (50.80)	N/A	N/A	350 (159)	3-7 (.02-.05)

Metric numbers are for reference only.

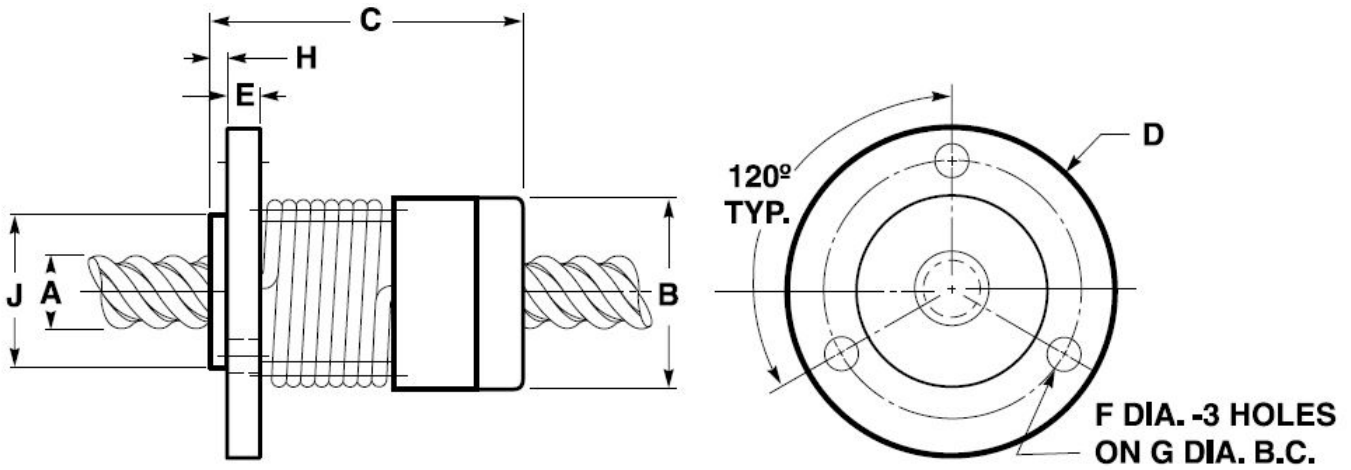

VHD Thread Mount

VHDT Tread Mount	Screw Diam. A	Nut Diam. B	Nut Length C	Thread M*	Thread Length N	Dynamic Load** lbs (Kg)	Drag Torque oz-in (N-m)
	inch (mm)	inch (mm)	inch (mm)	inch (mm)	inch (mm)		
	1/2 (13)	1.12 (28.5)	2.5 (64)	15/16-16	.50 (12.7)	150 (68)	2-6 (.014-.04)
	5/8 (16)	1.38 (35.1)	2.8 (72)	1 1/4-16	.50 (12.7)	250 (113)	2-6 (.014-.04)
	3/4 (19)	1.62 (41.2)	3.12 (79)	1 3/8-16	.50 (12.7)	350 (159)	3-7 (.02-.05)
	7/8 (22)	1.62 (41.2)	3.12 (79)	1 3/8-16	.50 (12.7)	350 (159)	3-7 (.02-.05)

Dimensional Tolerances		
Inches	Metric (mm)	
.X	± .02	< L 4 ± 0.1
.XX	± .010	4 < L ≤ 16 ± 0.15
.XXX	± .005	16 < L ≤ 63 ± 0.2
		63 < L ≤ 250 ± 0.3

Metric numbers are for reference only.

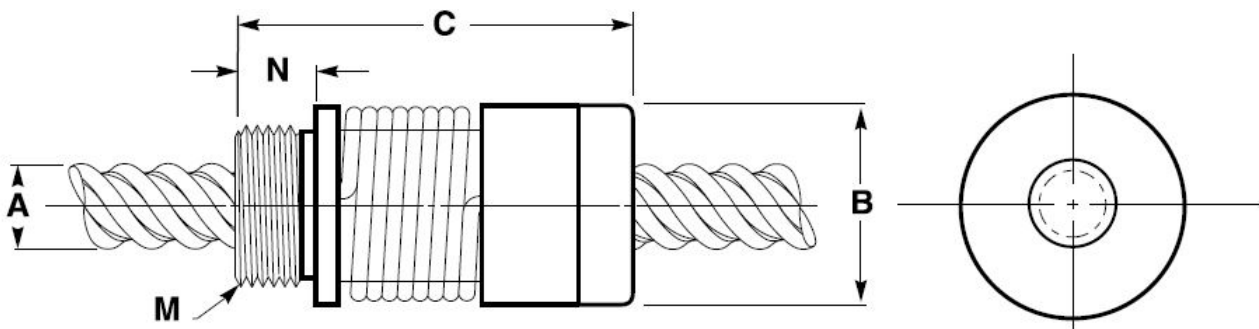

## VHD Nut Series - Maximum Load Anti-Backlash

### ■ Lead-Screw Compatibility: VHD Series

Diameter		Diameter Code	Lead		LEAD CODE	Left Hand Available	Outside Diameter (for reference)		Root Diameter (for reference)		Efficiency %*
inches	mm		inches	mm			inches	mm	inches	mm	
<b>1/2</b>	<b>13</b>	<b>050</b>	0.050	1.27	<b>0050</b>		0.495	12.57	0.433	11.00	29
			0.079	2.00	<b>0079</b>		0.473	12.01	0.355	9.02	41
			0.098	2.50	<b>0098</b>		0.500	12.70	0.383	9.73	46
			0.100	2.54	<b>0100</b>	•	0.490	12.45	0.364	9.25	46
			0.125	3.18	<b>0125</b>		0.500	12.70	0.374	9.50	51
			0.157	4.00	<b>0157</b>		0.500	12.70	0.384	9.75	58
			0.160	4.06	<b>0160</b>		0.500	12.70	0.388	9.86	67
			0.1667	4.23	<b>0167</b>		0.500	12.70	0.384	9.75	58
			0.197	5.00	<b>0197</b>		0.500	12.70	0.365	9.27	62
			0.200	5.08	<b>0200</b>	•	0.492	12.50	0.366	9.30	63
			0.250	6.35	<b>0250</b>		0.500	12.70	0.382	9.70	67
			0.333	8.46	<b>0333</b>	•	0.497	12.62	0.362	9.19	73
			0.394	10.00	<b>0394</b>		0.497	12.62	0.362	9.19	76
			0.400	10.16	<b>0400</b>		0.497	12.62	0.364	9.25	76
			0.500	12.70	<b>0500</b>		0.488	12.40	0.352	8.94	79
			0.630	16.00	<b>0630</b>		0.500	12.70	0.374	9.50	80
			0.750	19.05	<b>0750</b>		0.525	13.34	0.399	10.13	83
			0.800	20.32	<b>0800</b>		0.500	12.70	0.370	9.40	83
			0.984	25.00	<b>0984</b>		0.500	12.70	0.369	9.37	84
1.000	25.40	<b>1000</b>	•	0.490	12.45	0.372	9.45	84			
1.500	38.10	<b>1500</b>		0.490	12.45	0.374	9.50	85			
2.000	50.80	<b>2000</b>		0.488	12.40	0.378	9.60	87			
<b>5/8</b>	<b>16</b>	<b>062</b>	0.100	2.54	<b>0100</b>		0.615	15.62	0.498	12.65	40
			0.125	3.18	<b>0125</b>	•	0.625	15.88	0.470	11.94	45
			0.200	5.08	<b>0200</b>		0.625	15.88	0.495	12.57	53
			0.250	6.35	<b>0250</b>		0.625	15.88	0.469	11.91	63
			0.315	8.00	<b>0315</b>		0.627	15.93	0.493	12.52	68
			0.410	10.41	<b>0410</b>	•	0.625	15.88	0.481	12.22	72
			0.500	12.70	<b>0500</b>	•	0.625	15.88	0.478	12.14	76
			0.630	16.00	<b>0630</b>		0.625	15.88	0.491	12.47	78
			1.000	25.40	<b>1000</b>		0.625	15.88	0.481	12.22	83
			1.500	38.10	<b>1500</b>		0.625	15.88	0.499	12.67	85
			1.575	40.00	<b>1575</b>	•	0.625	15.88	0.499	12.67	86
			2.000	50.80	<b>2000</b>	•	0.625	15.88	0.499	12.67	86

Shaded areas have been translated from their designed inch or mm dimension to an equivalent mm or inch dimension.

\* Listed efficiencies are theoretical values based on Kerkote® TFE coated lead-screw  
 \*\* Listed efficiencies for Micro screws are theoretical values based on non-coated lead-screws

## VHD Nut Series - Maximum Load Anti-Backlash

### ■ Lead Screw Compatibility: VHD Series

Diameter		Diameter Code	Lead		LEAD CODE	Left Hand Available	Outside Diameter (for reference)		Root Diameter (for reference)		Efficiency %*
inches	mm		inches	mm			inches	mm	inches	mm	
<b>3/4</b>	<b>19</b>	<b>075</b>	0.0625	1.59	<b>0063</b>		0.750	19.05	0.671	17.04	25
			0.098	2.50	<b>0098</b>		0.742	18.85	0.626	15.90	35
			0.100	2.54	<b>0100</b>	•	0.746	18.95	0.624	15.85	35
			0.1667	4.23	<b>0167</b>		0.727	18.47	0.645	16.38	47
			0.197	5.00	<b>0197</b>		0.745	18.92	0.624	15.85	51
			0.200	5.08	<b>0200</b>		0.741	18.82	0.632	16.05	52
			0.250	6.35	<b>0250</b>		0.731	18.57	0.639	16.23	57
			0.276	7.00	<b>0276</b>		0.750	19.05	0.624	15.85	59
			0.333	8.46	<b>0333</b>		0.750	19.05	0.624	15.85	64
			0.394	10.00	<b>0394</b>		0.745	18.92	0.619	15.72	67
			0.500	12.70	<b>0500</b>		0.744	18.90	0.624	15.85	73
			0.551	14.00	<b>0551</b>		0.750	19.05	0.624	15.85	73
			0.591	15.00	<b>0591</b>		0.749	19.02	0.623	15.82	74
			0.709	18.00	<b>0709</b>		0.780	19.81	0.650	16.51	77
			0.748	19.00	<b>0748</b>		0.672	17.07	0.547	13.89	80
			0.787	20.00	<b>0787</b>		0.780	19.81	0.648	16.46	78
			0.800	20.32	<b>0800</b>		0.750	19.05	0.618	15.70	79
			0.945	24.00	<b>0945</b>	•	0.734	18.64	0.633	16.08	80
			1.000	25.40	<b>1000</b>	•	0.743	18.87	0.619	15.72	81
			1.500	38.10	<b>1500</b>		0.712	18.08	0.590	14.99	84
1.969	50.00	<b>1969</b>	•	0.751	19.08	0.620	15.75	84			
2.000	50.80	<b>2000</b>	•	0.742	18.85	0.611	15.52	84			
2.400	60.96	<b>2400</b>	•	0.750	19.05	0.620	15.75	84			
3.622	92.00	<b>3622</b>	•	0.750	19.05	0.634	16.10	87			
<b>7/8</b>	<b>22</b>	<b>087</b>	0.200	5.08	<b>0200</b>	•	0.870	22.10	0.742	18.85	48
			0.236	6.00	<b>0236</b>		0.848	21.54	0.773	19.63	52
			0.250	6.35	<b>0250</b>		0.875	22.23	0.749	19.02	53
			0.394	10.00	<b>0394</b>		0.875	22.23	0.741	18.82	65
			0.500	12.70	<b>0500</b>		0.862	21.89	0.744	18.90	69
			0.630	16.00	<b>0630</b>		0.875	22.23	0.741	18.82	73
			0.667	16.94	<b>0667</b>		0.871	22.12	0.745	18.92	74
			0.787	20.00	<b>0787</b>		0.875	22.23	0.741	18.82	78
			0.945	24.00	<b>0945</b>		0.875	22.23	0.741	18.82	79
1.000	25.40	<b>1000</b>		0.871	22.12	0.742	18.85	80			

Shaded areas have been translated from their designed inch or mm dimension to an equivalent mm or inch dimension.

\* Listed efficiencies are theoretical values based on Kerkote® TFE coated lead-screw

\*\* Listed efficiencies for Micro screws are theoretical values based on non-coated lead-screws

■ Material & Teflon TFE Coating Options

Materials		Teflon TFE Coatings	
<p><b>Kerkite® Composite Polymer Nuts</b></p>	<p>In addition to the Kerk® self-lubricating acetal nut material, we offer a variety of custom compounded Kerkite composite polymers. Kerkite polymers are a family of high performance materials that offer exceptional wear properties with the cost and design advantages afforded through injection molding. Kerkite polymers offer a variety of mechanical, thermal and electrical properties and are compatible with many chemicals and environmental conditions. Each member of the Kerkite family is compounded with lubricants, reinforcements and thermoplastic polymers formulated to provide optimum performance in its target conditions and applications.</p>	<p><b>Kerkote® TFE Coating</b></p>	<p>Soft coating that is a long-term, maintenance-free, dry lubricant, optimized for softer plastics like acetals and nylons, with or without mechanical reinforcement. Lubrication to the nut/screw interface occurs by the nut picking up Kerkote® TFE particles from the coating as well as from the migration of the internal lubricant within the plastic nut. The transfer of TFE to the nut continues throughout the operating life of the assembly as long as the nut periodically travels over areas with Kerkote® TFE coating. The lubricant, although solid, also has some “spreading” ability as in fluid lubricants. Kerkote® TFE coated screws provide the maximum level of self-lubrication and should not be additionally lubricated or used in environments where oils or other lubricant contamination is possible.</p>
<p><b>Special Materials</b></p>	<p>Kerk® has rolled screws in many materials, including 316 stainless, 400 series stainless, precipitate hardening materials, carbon steel, aluminum, and titanium. Kerk® nuts have been produced in many alternative plastics including PEEK, polyester, Torlon®, Vespel®, PVDF, UHMW, Ertalyte®, customer-supplied specialty materials, and metal nuts made from bronze, brass, and stainless steel. If the material can be molded, machined, ground, or rolled, we can likely process it.</p>	<p><b>Black Ice® TFE Coating</b></p>	<p>Hard coating that is long term, maintenance-free and is exceptionally durable in all types of environments, with virtually any type of polymer nut. Black Ice® TFE coating remains on the screw, offering a low friction surface upon which the nut travels. Rather than acting as a dry lubricant, Black Ice® TFE is an anti-friction coating whose surface properties displace the metal to which it is applied. Though it is not intended for use with metal or glass fiber reinforced nuts, Black Ice® TFE is bonded securely to the screw’s surface and can withstand abrasion from contamination, rigid polymer systems, fluid impingement and wash down applications. Black Ice® TFE can be used in more aggressive environment conditions, or anywhere reduced friction and a permanent coating is desired. Not intended to be used with additional lubricants.</p>

**Note:** There are certain applications where external lubrication may be desired. These include the use of nut materials such as glass reinforced plastic or metal. Greases, when used properly can provide unique capabilities and Haydon Kerk Motion Solutions does offer a selection of greases developed specifically for these applications. Please contact a sales engineer for assistance selecting the best lubricant for your requirements.