

RGS04 Non-Motorized Linear Rails

Screw driven linear rail or linear rail without screw

The non-motorized RGS Series features standard wear compensating, anti-backlash driven carriages to ensure repeatable and accurate positioning. All moving surfaces include Kerkite® engineered polymers running on Kerkote® TFE coating, providing a strong, stable platform for a variety of linear motion applications.



RGS04 Non-Motorized Screw Driven Linear Rail

Identifying the Non-Motorized RGS Part Numbers when Ordering

RG	S	04	K	A	0100	XXX
Prefix RG = Rapid Guide Screw	Frame Style S = Standard	Frame Size Load 04 = 15 lbs (67 N) (Maximum static load)	Coating K = TFE Kerkote X = Special (example: Kerkote with grease)	Drive / Mounting A = None	Nominal Thread Lead Code 0000 = No Screw 0100 = .100-in (2.54) 0200 = .200-in (5.08) 0500 = .500-in (12.70) 1000 = 1.000-in (2.54)	Unique Identifier Suffix used to identify specific motors or a proprietary suffix assigned to a specific customer application. The identifier can apply to either a standard or custom part

NOTE: Dashes must be included in Part Number (-) as shown above. For assistance call our Engineering Team at 603 213 6290. Carriage holes available in metric sizes M3, M4.

Specifications

	Inch Lead	Thread Lead Code	Nominal Rail Diam.	Nominal Screw Diam.	Typical Drag Torque	Life @ 1/4 Design Load*	Torque-to-Move Load	Design Load	Screw Inertia
RGS04 Non-Motorized with Guide Screw	inch (mm)		inch (mm)	inch (mm)	oz - in (N-m)	inch (cm)	oz-inc/lb (Nm/Kg)	lbs (N)	oz-in-sec ² /in (kg-m-sec ² /m)
	.100 (2.54)	0100	0.4 (10.2)	1/4 (6.4)	3.0 (0.2)	100,000,000 (254,000,000)	1.0 (.016)	15 (67)	.3 x 10 ⁻⁵ (6.5 x 10 ⁻⁶)
	.200 (5.08)	0200			4.0 (.03)		1.5 (.023)		
	.500 (12.70)	0500			5.0 (.04)		2.5 (.039)		
	1.000 (25.40)	1000			6.0 (.04)		4.5 (.070)		

NOTE: RGS assemblies with lengths over 36 inches (914.4 mm) and/or leads higher than .5 inch (12.7 mm) will likely have higher drag torque than listed values.

*Determined with load in a horizontal position.

Non-Motorized with Guide Screw Dimensional Drawings

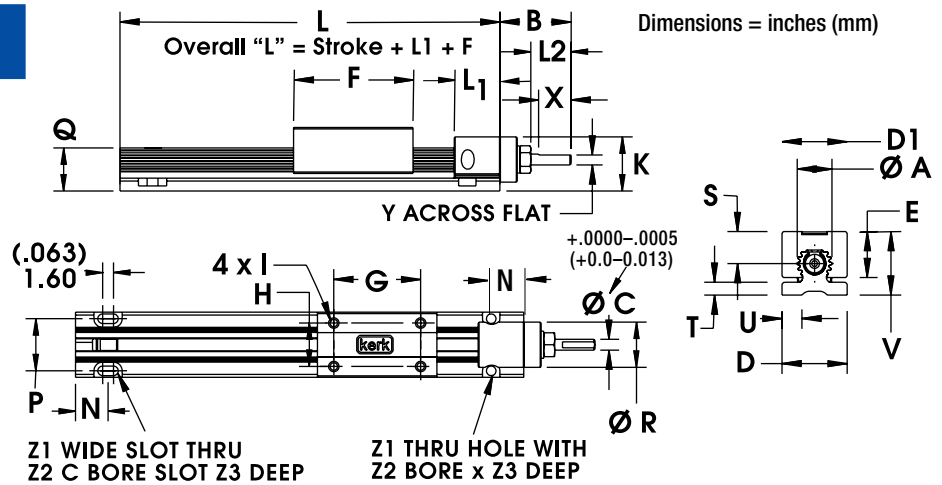

	A	B	C	D	D1	E	F	G	H	I*	K	L1	L2	N	P	Q	R	S	T	U	V	X	Z1	Z2	Z3
inch	0.40	.83	.1250	0.75	0.75	0.53	1.38	1.00	0.50	4.40	0.6	.53	.47	.375	.60	.50	.52	0.37	0.15	0.23	0.7	.38	0.115	0.20	0.09
mm	10.2	21.1	3.175	19.1	19.1	13.5	35.1	25.4	12.7	UNC	15	13.5	11.9	9.53	15.24	12.7	13.2	9.4	3.8	5.8	18.0	9.7	2.92	5.1	2.3

*Metric carriage hole sizes available M3, M4.

Non-Motorized without Guide Screw
Dimensional Drawings



RGS04 Non-Motorized
Linear Rail without Screw

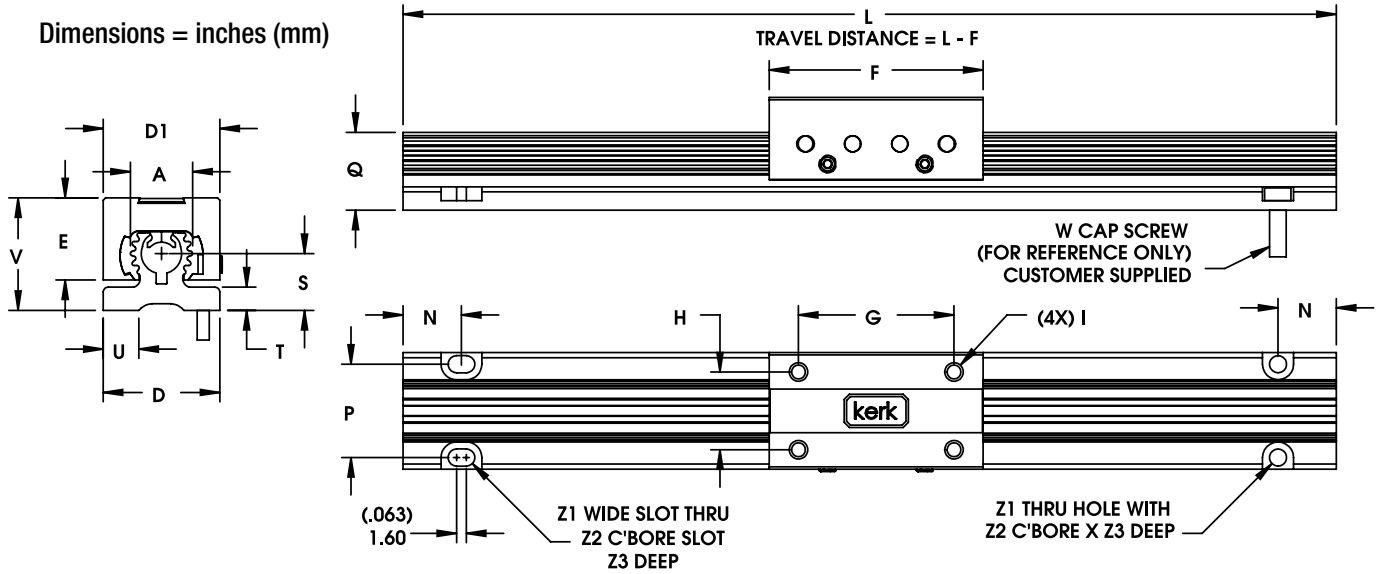

	A	D	D1	E	F	G	H	I*	N	P	Q	S	T	U	V	Z1	Z2	Z3
inch	0.40	0.75	0.75	0.53	1.4	1.00	0.50	4-40	.375	.60	.50	0.37	0.15	0.23	0.7	0.11	0.20	0.09
mm	10.2	19.1	19.1	13.5	36	25.4	12.7	UNC	9.53	15.24	12.7	9.4	3.8	5.8	18.0	2.8	5.1	2.3

*Metric carriage hole sizes available M3, M4.

[Linear Rail Check List](#)

Material Coatings

Kerkite® Polymers

Compounded with lubricants, reinforcements and thermoplastic polymers, Kerkite Polymers are formulated to provide optimum performance in its target conditions and applications.

- Injection molded
- High performance
- Exceptional wear properties

Kerkote® TFE Coating

A dry lubricant, Kerkote will not become dry and paste-like, and does not attract dirt or debris. Kerkote differs from conventional plating and coating because it is soft, more evenly distributed than other lubricants, and decreases erratic drag torques and unpredictable wear.

- Reduces friction
- Cost effective
- Long term and maintenance free

Kerkote provides the maximum level of self-lubrication, requiring no additional external lubrication or maintenance.