

Max Series

30% performance increase compared to standard Size 17

M43000 Max Series Single Stack Size 17 Max Hybrid Linear Actuators

Our best selling compact hybrid motors, now with 30% performance increase

Top selling designs deliver high performance, opening avenues for equipment designers who previously settled for products with inferior performance and endurance.

3 Available Designs

- Captive
- Non-Captive
- External Linear

The M43000 Max Series is available in a wide variety of resolutions - from 0.00006-in. (.001524 mm) per step to 0.00192-in. (.048768 mm) per step, and delivers thrust of up to 50 lbs. (222 N), or speeds exceeding 3 inches (7.62 cm) per second.

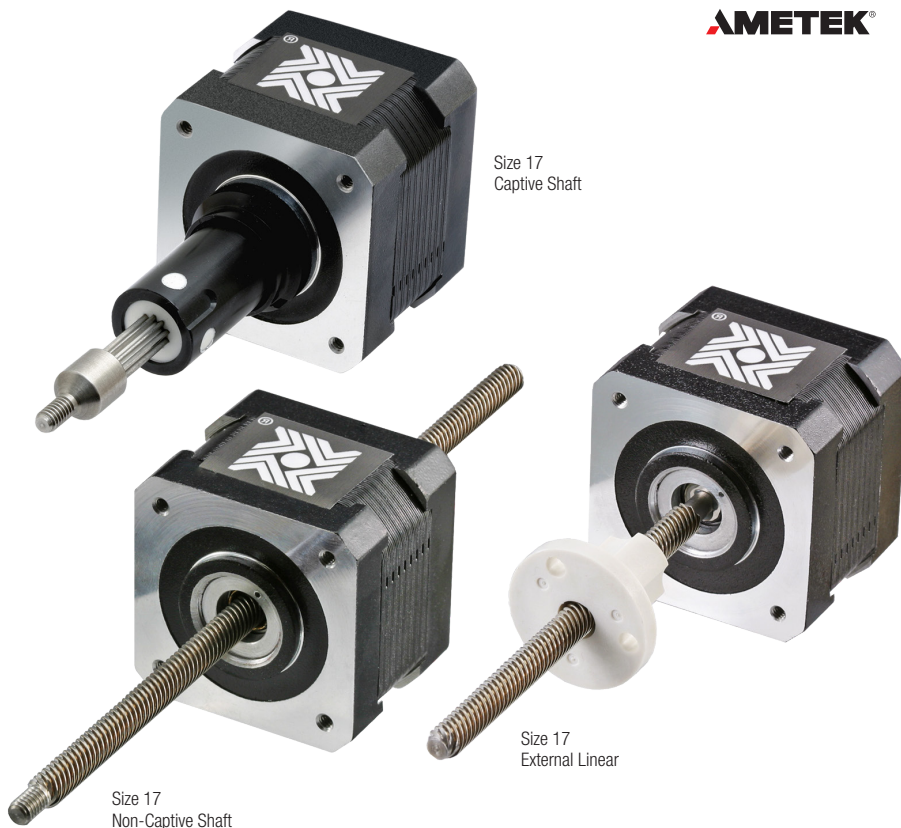

| Size 17 Max: 43 mm (1.7-in) Hybrid Linear Actuator (1.8° Step Angle) | | | | | | |
|--|-----------------------------|-----------|----------|------------|-----------|--|
| Part No. | Captive | M43H4 † | | | M43H6 † | |
| | Non-Captive | M43F4 † | | | M43F6 † | |
| | External Linear | EM43H4 † | | | EM43H6 † | |
| Wiring | Bipolar | | | Unipolar** | | |
| Winding Voltage | 2.8 VDC | 5.8 VDC | 13.8 VDC | 5.8 VDC | 13.8 VDC | |
| Current (RMS)/phase | 1.5 A | 700 mA | 290 mA | 700 mA | 290 mA | |
| Resistance/phase | 1.77 Ω | 8.3 Ω | 47.6 Ω | 8.3 Ω | 47.6 Ω | |
| Inductance/phase | 2.45 mH | 13.5 mH | 88.0 mH | 6.75 mH | 44.0 mH | |
| Power Consumption | 8 W | | | | | |
| Rotor Inertia | 37.1 gcm ² | | | | | |
| Temperature Rise | 135° F Rise (70° C Rise) | | | | | |
| Insulation Class | Class B (Class F available) | | | | | |
| Weight | 9 oz (255 g) | | | | | |
| Insulation Resistance | 20 MΩ | | | | | |

†Part numbering information on page 7. ** Unipolar drive gives approximately 30% less thrust than bipolar drive.

| Linear Travel / Step | | Order Code I.D. |
|-------------------------|--------|-----------------|
| Screw Ø .218" (5.54 mm) | | |
| inches | mm | |
| .00012 | .0030* | N |
| .00024 | .0060* | K |
| .00048 | .0121* | J |
| .00096 | .0243* | Q |
| .00192 | .0487* | R |

| Linear Travel / Step | | Order Code I.D. |
|-------------------------|--------|-----------------|
| Screw Ø .250" (6.35 mm) | | |
| inches | mm | |
| .00015625 | .0039* | P |
| .0003125 | .0079* | A |
| .000625 | .0158* | B |
| .00125 | .0317* | C |

*Values truncated.

Standard motors are Class B rated for maximum temperature of 130°C. Also available, motors with high temperature capability windings up to 155°C.

Special drive considerations may be necessary when leaving shaft fully extended or fully retracted.

Captive Lead Screw

Dimensions = (mm) inches

Integrated connector option available

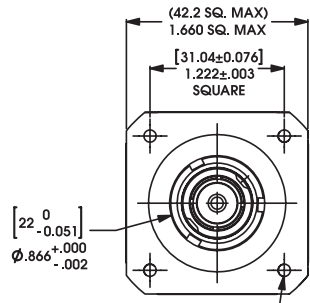

4X #4-40 UNC-2B (STANDARD INCH) OR 4X M3 x 0.5-6g (STANDARD METRIC) THREAD x 0.15 (3.8) DEEP (MUST BE SPECIFIED WHEN ORDERING)
M3 MOUNTING HOLES AVAILABLE ON REQUEST.

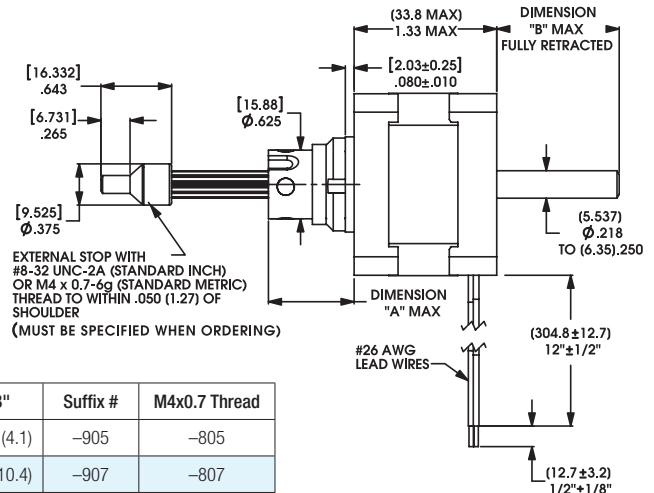

| Stroke | Dim. "A" | Dim. "B" | Suffix # | M4x0.7 Thread |
|---------------|-------------|-------------|----------|---------------|
| 0.500 (12.7) | 0.78 (19.8) | 0.16 (4.1) | -905 | -805 |
| 0.750 (19.05) | 1.03 (26.2) | 0.41 (10.4) | -907 | -807 |
| 1.000 (25.4) | 1.28 (32.5) | 0.66 (16.8) | -910 | -810 |
| 1.250 (31.8) | 1.53 (38.9) | 0.91 (23.1) | -912 | -812 |
| 1.500 (38.1) | 1.78 (45.2) | 1.16 (29.5) | -915 | -815 |
| 2.00 (50.8) | 2.28 (57.9) | 1.66 (42.2) | -920 | -820 |
| 2.500 (63.5) | 2.78 (70.6) | 2.16 (54.9) | -925 | -825 |

Non-Captive Lead Screw

Dimensions = (mm) inches

Integrated connector option available

4-in [101.6 mm] standard screw lengths. Longer screw lengths are available.

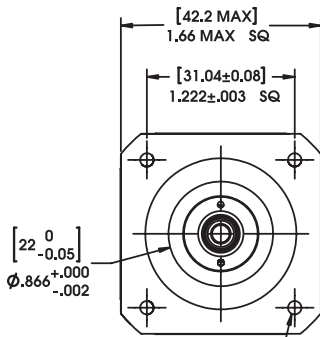

4X #4-40 UNC-2B (STANDARD INCH) OR 4X M3 x 0.5-6g (STANDARD METRIC) THREAD x 0.15 (3.8) DEEP (MUST BE SPECIFIED WHEN ORDERING)

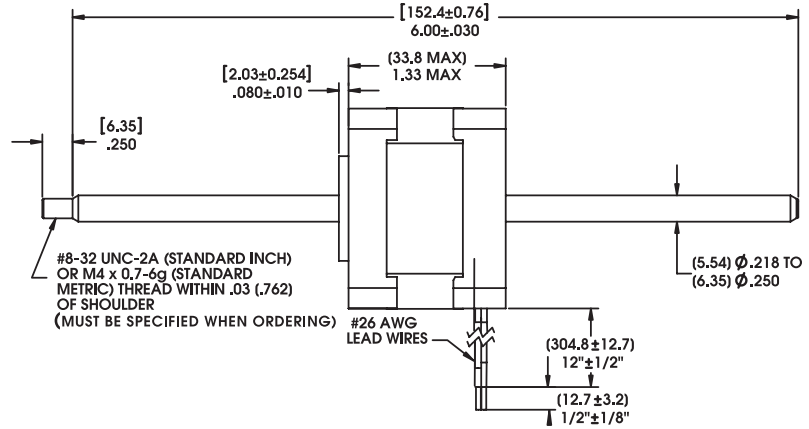

External Linear

Dimensions = (mm) inches

Integrated connector option available

4-in [101.6 mm] standard screw lengths. Longer screw lengths are available.

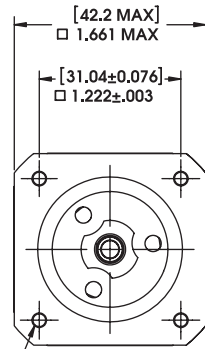

4X #4-40 UNC-2B (STANDARD INCH) OR 4X M3 x 0.5-6g (STANDARD METRIC) THREAD x 0.15 (3.8) DEEP (MUST BE SPECIFIED WHEN ORDERING)

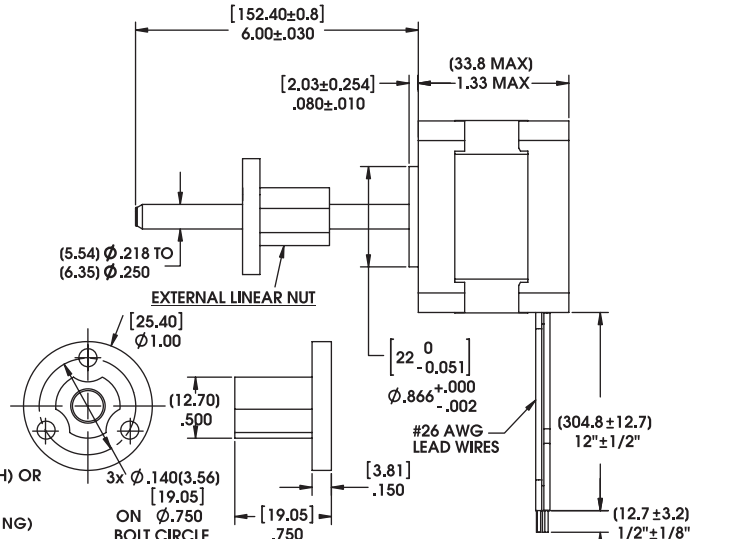

FORCE vs. PULSE RATE – Chopper – Bipolar – 100% Duty Cycle – 8:1 Motor Coil to Drive Supply Voltage

– Ø .218 (5.54) Lead Screw

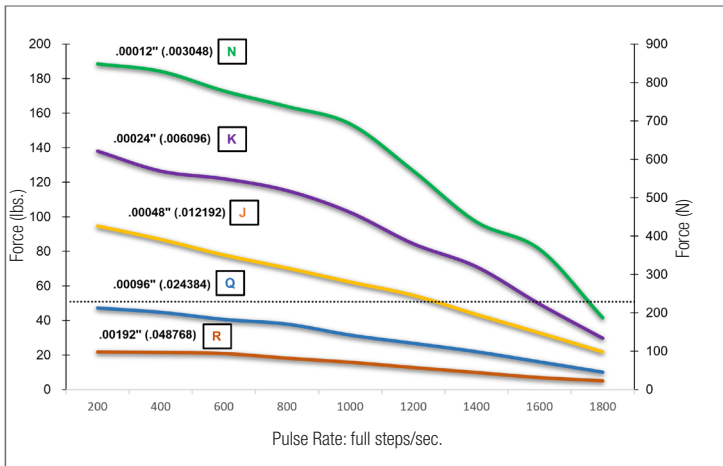

– Ø .250 (6.35) Lead Screw

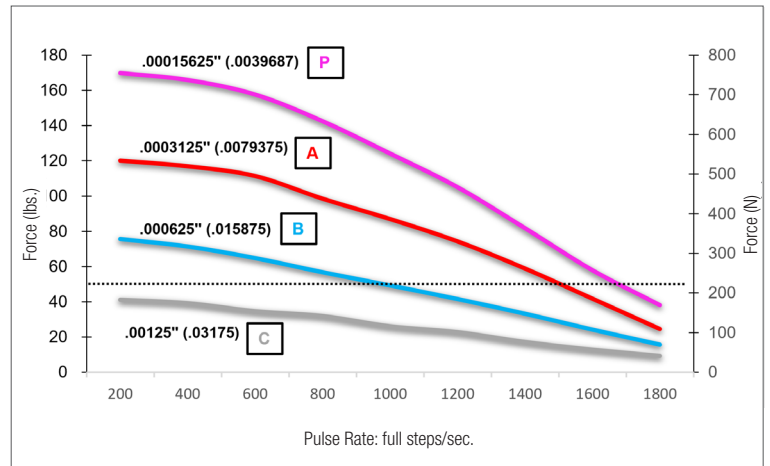

FORCE vs. LINEAR VELOCITY – Chopper – Bipolar – 100% Duty Cycle – 8:1 Motor Coil to Drive Supply Voltage

– Ø .218 (5.54) Lead Screw

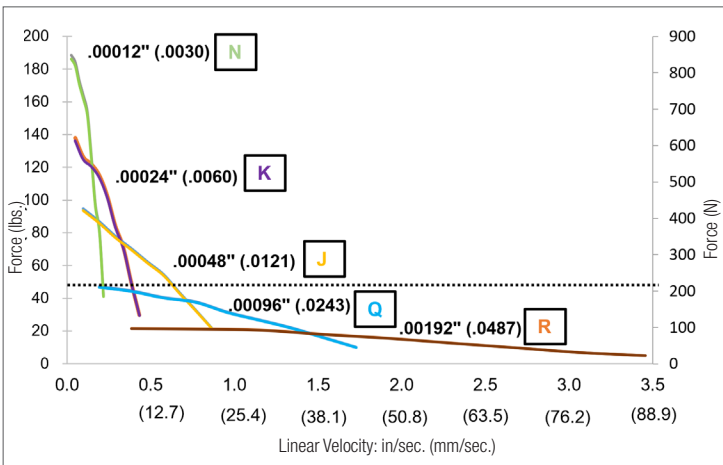

– Ø .250 (6.35) Lead Screw

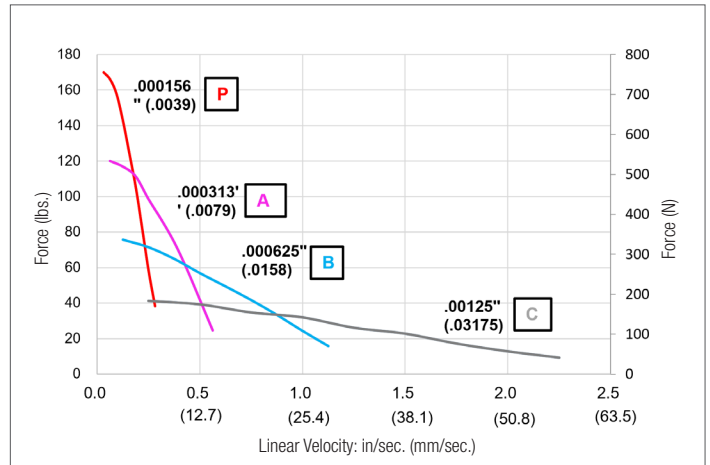

NOTE: All chopper drive curves were created with a 5.8 volt, 1/2 microstepping motor and a 40 volt power supply.





Ramping can increase the performance of a motor either by increasing the top speed or getting a heavier load accelerated up to speed faster. Also, deceleration can be used to stop the motor without overshoot.

With L/R drives peak force and speeds are reduced, using a unipolar drive will yield a further 30% force reduction.

M43000 Series

Size 17, 0.9° High Resolution Motor

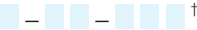
The Size 17 Max High Resolution Actuator features a production-proven, patented rotor drive nut that delivers trouble-free, long-term performance.

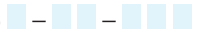
| Size 17 Max: 43 mm (1.7-in) Hybrid Linear Actuator (0.9° Step Angle) | | | | | | |
|--|-----------------------------|--|----------|---------|---|--|
| Part No. | Captive | M43K4  † | | | M43K6  † | |
| | Non-Captive | M43J4  † | | | M43J6  † | |
| | External Linear | EM43K4  † | | | EM43K6  † | |
| Wiring | | Bipolar | | | Unipolar** | |
| Winding Voltage | 2.8 VDC | 5.8 VDC | 13.8 VDC | 5.8 VDC | 13.8 VDC | |
| Current (RMS)/phase | 1.5 A | 700 mA | 290 mA | 700 mA | 290 mA | |
| Resistance/phase | 1.77 Ω | 8.3 Ω | 47.6 Ω | 8.3 Ω | 47.6 Ω | |
| Inductance/phase | 3.2 mH | 17.7 mH | 116.2 mH | 8.85 mH | 58.1.0 mH | |
| Power Consumption | 8 W | | | | | |
| Rotor Inertia | 37.1 gcm ² | | | | | |
| Insulation Class | Class B (Class F available) | | | | | |
| Weight | 9 oz (241 g) | | | | | |
| Insulation Resistance | 20 MΩ | | | | | |

†Part numbering information on page 7. **Unipolar drive gives approximately 30% less thrust than bipolar drive.

| Linear Travel / Step | | Order Code I.D. |
|-------------------------|--------|-----------------|
| Screw Ø .218" (5.54 mm) | | |
| inches | mm | |
| .00006 | .0015* | U |
| .00012 | .0030* | N |
| .00024 | .0060* | K |
| .00048 | .0121* | J |
| .00096 | .0243* | Q |

| Linear Travel / Step | | Order Code I.D. |
|-------------------------|---------|-----------------|
| Screw Ø .250" (6.35 mm) | | |
| inches | mm | |
| .000078* | .00198* | V |
| .00015625 | .0039* | P |
| .0003125 | .0079* | A |
| .000625 | .0158* | B |

*Values truncated.

Standard motors are Class B rated for maximum temperature of 130°C.

NOTE: Refer to performance curves on page 3 for codes N, K, J, Q, P, A, B

Special drive considerations may be necessary when leaving shaft fully extended or fully retracted.

FORCE vs. PULSE RATE – Chopper – Bipolar – 100% Duty Cycle
– 8:1 Motor Coil to Drive Supply Voltage
with two available lead screw diameters

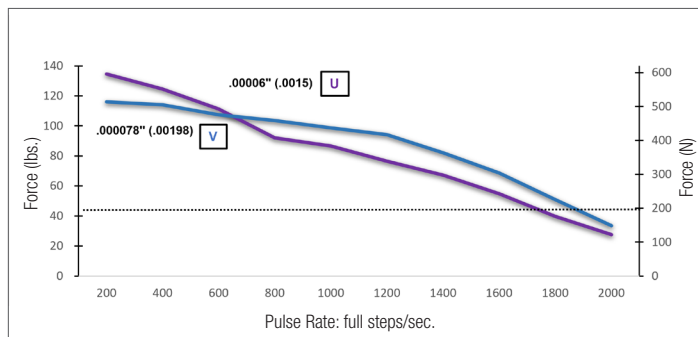

FORCE vs. LINEAR VELOCITY – Chopper – Bipolar – 100% Duty Cycle
– 8:1 Motor Coil to Drive Supply Voltage
with two available lead screw diameters

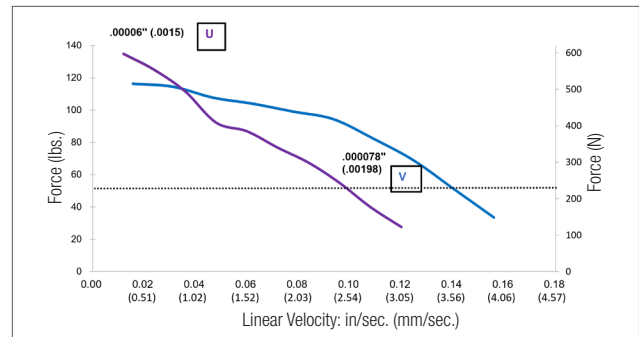

NOTE: All chopper drive curves were created with a 5.8 volt, 1/2 microstepping motor and a 40 volt power supply.

Ramping can increase the performance of a motor either by increasing the top speed or getting a heavier load accelerated up to speed faster. Also, deceleration can be used to stop the motor without overshoot.

With L/R drives peak force and speeds are reduced, using a unipolar drive will yield a further 30% force reduction.

M43000 Series Size 17 Hybrid Linear Actuators with integrated IDEA™ Drive

High performance in a compact package

The M43000 Max Series Single Stack actuator is available in a wide variety of resolutions – from 0.00006-in (.001524 mm) per step to 0.00192-in (.048768mm) per step. Delivers output force of up to 50 lbs (220N), or speeds exceeding 3 inches (7.62 cm) per second.

M43000 Max Series with IDEA™ Drive features:

- Fully Programmable
- RoHS Compliant
- USB or RS-485 Communication
- Microstepping Capability: Full, 1/2, 1/4, 1/8, 1/16, 1/32, 1/64
- Graphic User Interface
- Auto-population of Drive Parameters
- Programmable Acceleration/Deceleration and Current Control

3 Available Designs

- Captive – Non-Captive – External Linear



NOTE: For more information see the Haydon Kerk IDEA™ Drive Data Sheet.

| Size 17 Single Stack Max: 43 mm (1.7-in) Hybrid Linear Actuator (1.8° Step Angle) | | |
|---|-----------------|-----------|
| Part No. | Captive | M43HG † |
| | Non-Captive | M43FG † |
| | External Linear | EM43HG † |
| Wiring | Bipolar | |
| Winding Voltage | 2.8 VDC** | |

†Part numbering information on page 7. **Contact Haydon Kerk if a higher voltage motor is desired. Special drive considerations may be necessary when leaving shaft fully extended or fully retracted.

| Linear Travel / Step | | Order Code I.D. |
|-------------------------|--------|-----------------|
| Screw Ø .218" (5.54 mm) | | |
| inches | mm | |
| .00012 | .0030* | N |
| .00024 | .0060* | K |
| .00048 | .0121* | J |
| .00096 | .0243* | Q |
| .00192 | .0487* | R |

| Linear Travel / Step | | Order Code I.D. |
|-------------------------|--------|-----------------|
| Screw Ø .250" (6.35 mm) | | |
| inches | mm | |
| .00015625 | .0039* | P |
| .0003125 | .0079* | A |
| .000625 | .0158* | B |
| .00125 | .0317* | C |

*Values truncated.

Simple to use IDEA™ Drive software with on-screen buttons and easy-to-understand programming guides

Software program generates motion profiles directly into the system and also contains a “debug” utility allowing line-by-line execution of a motion program for easy troubleshooting.

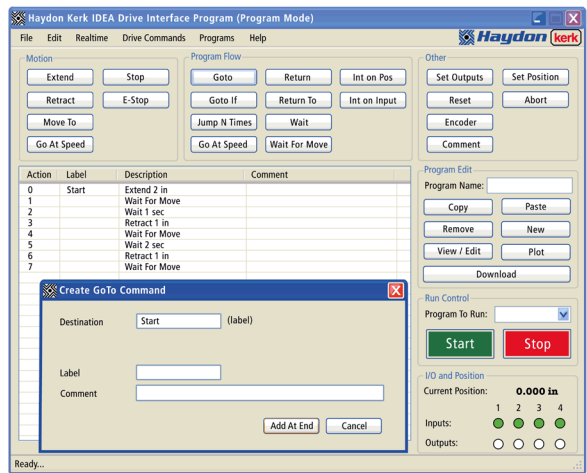

Captive Lead Screw

Dimensions = (mm) inches

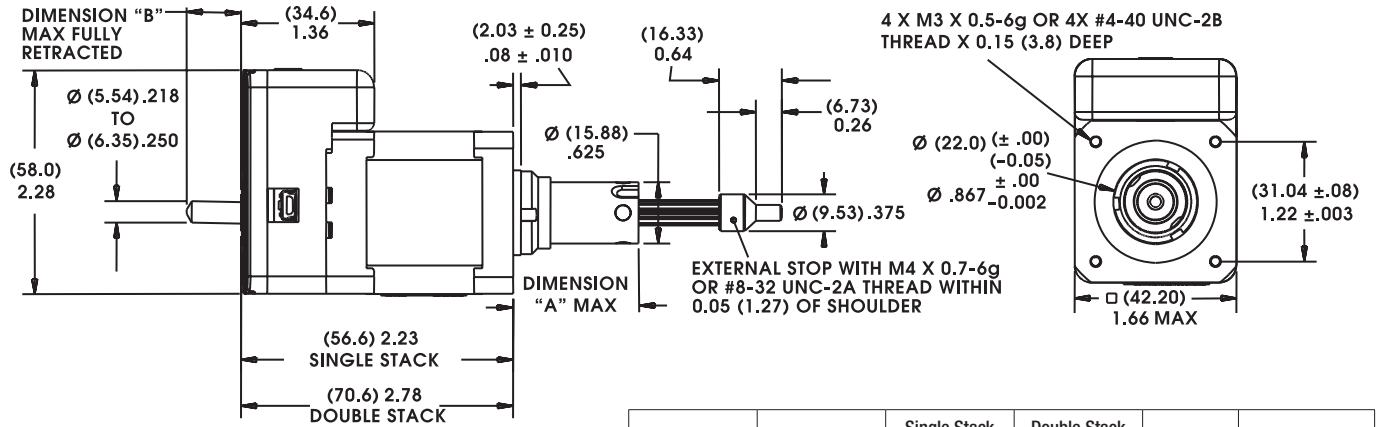

| Stroke | Dim. "A" | Single Stack Dim. "B" | Double Stack Dim. "B" | Suffix # | M4x0.7 Thread |
|---------------|-------------|-----------------------|-----------------------|----------|---------------|
| 0.500 (12.7) | 0.78 (19.8) | 0 | 0 | -905 | -805 |
| 0.750 (19.05) | 1.03 (26.2) | 0 | 0 | -907 | -807 |
| 1.000 (25.4) | 1.28 (32.5) | 0 | 0 | -910 | -810 |
| 1.250 (31.8) | 1.53 (38.9) | 0 | 0 | -912 | -812 |
| 1.500 (38.1) | 1.78 (45.2) | 0.232 (5.9) | 0.091 (2.5) | -915 | -815 |
| 2.00 (50.8) | 2.28 (57.9) | 0.732 (18.6) | 0.591 (15.0) | -920 | -820 |
| 2.500 (63.5) | 2.78 (70.6) | 1.232 (31.3) | 1.091 (27.7) | -925 | -825 |

Non-Captive Lead Screw

Dimensions = (mm) inches

Up to 10-in (254 mm) standard screw lengths. Longer screw lengths are available.

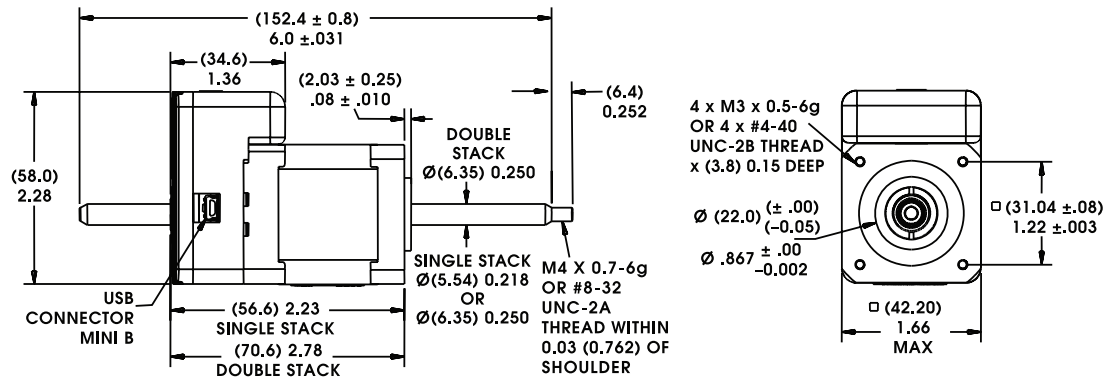

External Linear

Dimensions = (mm) inches

Up to 10-in (254 mm) standard screw lengths. Longer screw lengths are available.

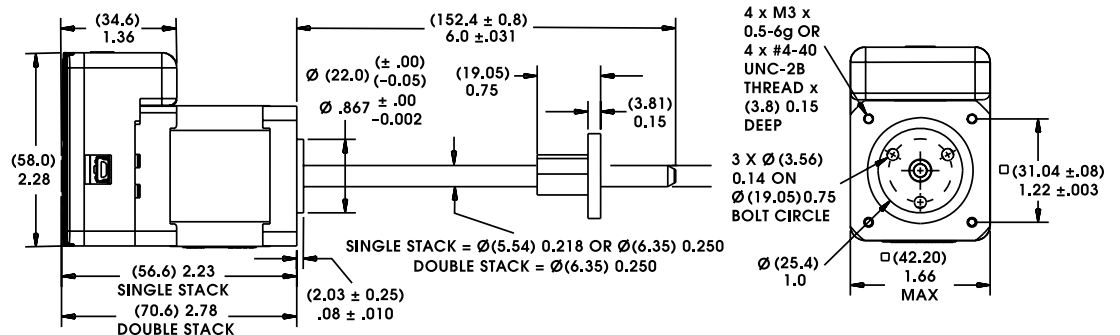

Identifying the Hybrid Part Number Codes when Ordering

| E | M43 | H | 6 | N | 2.8 | 910 |
|--|--|--|--|--|--|---|
| Prefix (include only when using the following) A = A Coil (See AC Synchronous Data Sheet) E = External K = External with 40° thread form P = Proximity Sensor S = Home Position Switch | Series Number Designation M43 = 43000 Max Series (Series numbers represent approximate width of motor body) | Style F = 1.8° Non-captive H = 1.8° Captive or External (use "E" or "K" Prefix for External version) J = 0.9° Non-captive K = 0.9° Captive or External (use "E" or "K" Prefix for External version) | Coils 4 = Bipolar (4 wire) 6 = Unipolar (6 wire) G = IDEA Drive (Size 17, 43000 Series, Bipolar only) | Code ID Resolution Travel/Step N = .00012-in (.0030) K = .00024-in (.0060) J = .00048-in (.0121) Q = .00096-in (.0243) P = .0015625-in (.0039) A = .003125-in (.0079) B = .00625-in (.0158) C = .0125-in (.0317) R = .0192-in (.0478) High Resolution U = .00006-in (.0015) V = .000078-in (.00198) | Voltage 2.8 = 2.8 VDC 5.8 = 5.8 VDC 13.8 = 13.8 VDC Custom V available | Suffix Stroke Example: -910 = 1-in (Refer to Stroke chart on Captive motor series product page.) Suffix also represents: -800 = Metric -900 = External Linear with grease and flanged nut -XXX = Proprietary suffix assigned to a specific customer application. The identifier can apply to either a standard or custom part. |

NOTE: Dashes must be included in Part Number (-) as shown above. For assistance call our Engineering Team at 203 756 7441.

Hybrids: **Wiring**

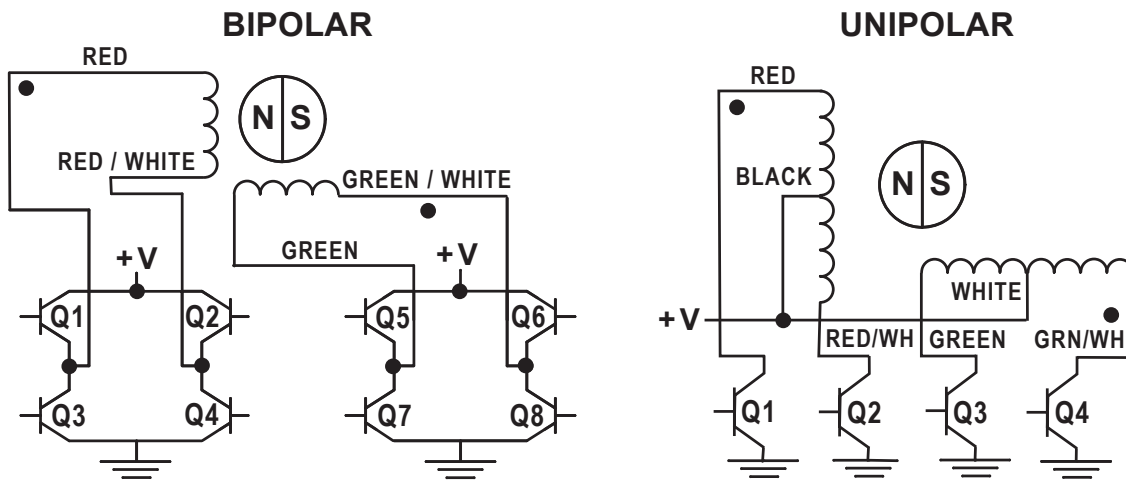

Hybrids: **Stepping Sequence**

| | Bipolar | Q2-Q3 | Q1-Q4 | Q6-Q7 | Q5-Q8 |
|------|---------|-------|-------|-------|-------|
| Step | | | | | |
| 1 | | ON | OFF | ON | OFF |
| 2 | | OFF | ON | ON | OFF |
| 3 | | OFF | ON | OFF | ON |
| 4 | | ON | OFF | OFF | ON |
| 1 | | ON | OFF | ON | OFF |

EXTEND CW ↓ ↑ RETRACT CCW

Note: Half stepping is accomplished by inserting an off state between transitioning phases.

Encoders Designed for All Sizes of Hybrid Linear Actuators

All Haydon Hybrid Linear Actuators are available with specifically designed encoders for applications that require feedback. The compact optical incremental encoder design is available with two channel quadrature TTL squarewave outputs. An optional index is also available as a 3rd channel. The Size 17 Encoder provides resolutions for applications that require 200, 400 and 1,000 counts per revolution. Encoders are available for all motor configurations.

Simplicity and low cost make the encoders ideal for both high and low volume motion control applications. The internal monolithic electronic module converts the real-time shaft angle, speed, and direction into TTL compatible outputs. The encoder module incorporates a lensed LED light source and monolithic photodetector array with signal shaping electronics to produce the two channel bounceless TTL outputs.

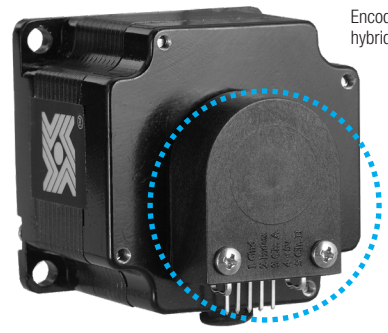

Encoder on Size 23 hybrid motor

30 mm M43000 Series Size 17

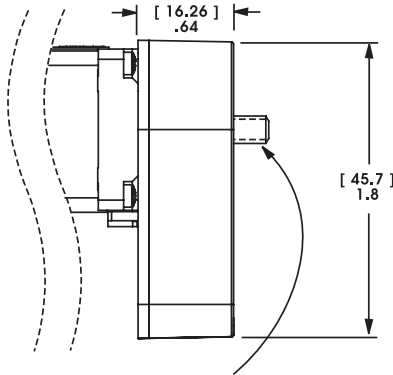

NOTE: Lead Screw extends beyond encoder on specific captive and non-captive motors. External linear shaft extension is available upon request.

Differential Ended Encoder - Pinout - Size 17

| Connector Pin # | Description |
|-----------------|--------------|
| 1 | Ground |
| 2 | Ground |
| 3 | - Index |
| 4 | + Index |
| 5 | Channel A - |
| 6 | Channel A + |
| 7 | +5 VDC Power |
| 8 | +5 VDC Power |
| 9 | Channel B - |
| 10 | Channel B + |

Electrical Specifications

| | Minimum | Typical | Maximum | Units |
|----------------|---------|---------|---------|-------|
| Input Voltage | 4.5 | 5.0 | 5.5 | VDC |
| Output Signals | 4.5 | 5.0 | 5.5 | VDC |

2 channel quadrature TTL squarewave outputs.

Channel B leads A for a clockwise rotation of the rotor viewed from the encoder cover.

Tracks at speeds of 0 to 100,000 cycles/sec.

Optional index available as a 3rd channel (one pulse per revolution).

Operating Temperature

| Size 17 | Minimum | Maximum |
|---------|-----------------|---------------|
| | - 40°C (- 40°F) | 100°C (212°F) |

Mechanical Specifications

| | Maximum |
|---------------------------|------------------------------|
| Acceleration | 250,000 rad/sec ² |
| Vibration (5 Hz to 2 kHz) | 20 g |

Resolution

4 Standard Cycles Per Revolution (CPR) or Pulses Per Revolution (PPR)

| Size 17 | CPR | 200 | 400 | 1000* |
|---------|-----|-----|------|-------|
| | PPR | 800 | 1600 | 4000* |

*Index Pulse Channel not available.

Single Ended Encoder - Pinout - Size 17

| Connector Pin # | Description | Connector Pin # | Description |
|-----------------|------------------|-----------------|--------------|
| 1 | Ground | 4 | +5 VDC Power |
| 2 | Index (optional) | 5 | Channel B |
| 3 | Channel A | | |

Integrated Connectors

Hybrid Size 17 Max linear actuators are available with an integrated connector. Offered alone or with a harness assembly, this connector is RoHS compliant and features a positive latch in order for high connection integrity. The connector is rated up to 3 amps and the mating connector will handle a range of wire gauges from 22 to 28. This motor is ideal for those that want to plug in directly to pre-existing harnesses.

Motor Connector:

JST part # S06B-PASK-2

Mating Connector:

JST part # PAP-06V-S

Haydon Kerk Part #56-1210-5 (12 in. Leads)

Wire to Board Connector:

JST part number SPHD-001T-P0.5

| Pin # | Bipolar | Unipolar | Color |
|-------|----------------|----------------|-------|
| 1 | Phase 2 Start | Phase 2 Start | G/W |
| 2 | Open | Phase 2 Common | - |
| 3 | Phase 2 Finish | Phase 2 Finish | Green |
| 4 | Phase 1 Finish | Phase 1 Finish | R/W |
| 5 | Open | Phase 1 Common | - |
| 6 | Phase 1 Start | Phase 1 Start | Red |

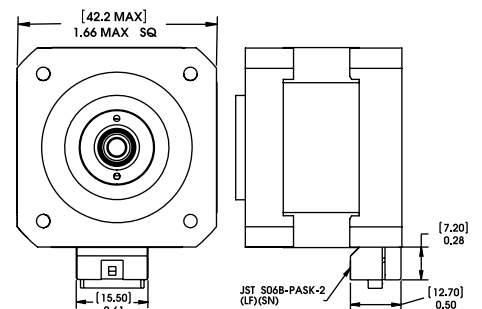

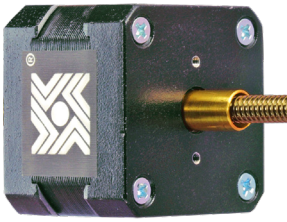

Encoder Ready Option Shown 43000 Series Size 17

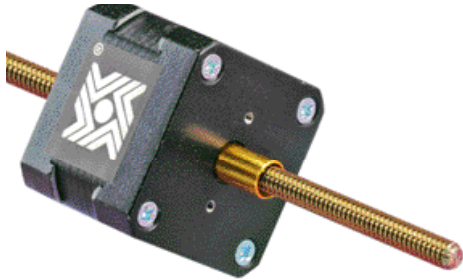

Extended Rotor Journal Shown 43000 Series Size 17

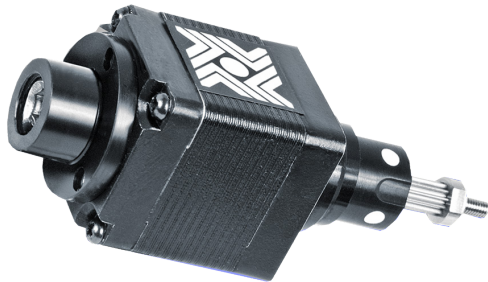

End of Stroke Proximity Sensor



TFE Coated Lead Screw

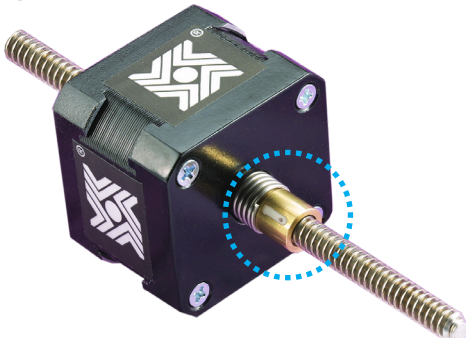

Integrated Anti-Backlash Nut

Encoder Ready Option for all Hybrid Sizes

Our Hybrid Linear Actuators can now be manufactured as an Encoder Ready Actuator. Encoder Ready Actuators can be used to install several popular hollow shaft encoders. Available with an extended rotor journal and a threaded rear housing. The motor uses a proprietary manufacturing process which incorporates engineering thermoplastics in the rotor drive nut and a stainless steel Acme Lead Screw that allows the motor to be much more efficient and durable than today's more commonly used V-thread bronze nut configurations.

Size 23 Mounting Face Plate for Size 17 Hybrids

Size 23 mounting pattern for our Hybrid Size 17 Linear Actuators.

Extended Rotor Journal for all Hybrid Sizes

Available with an extended rotor journal. The extended rotor journal can be used for encoder installation, manual adjustment, or flag installation for a positioning sensor.

Home Position Switch for Hybrids

A miniature electronic Home Position Switch capable of monitoring the home positions of linear actuators. The switch mounts on the rear sleeve of captive linear motors and allows the user to identify start, stop or home positions.

When ordering motors with the home position switch the part number should be preceded by an "S" prefix.

End of Stroke Proximity Sensor for all Hybrid Sized

The Sensor incorporates a hall effect device, which is activated by a rare earth magnet embedded in the end of the internal screw. The compact profile of the sensor allows for installation in limited space applications. The sensor has a virtually unlimited cycle life. Special cabling and connectors can also be provided.

When ordering motors with the proximity sensor, the part number should be preceded by a "P" prefix.

Black Ice® and Kerkote® TFE Coated Lead Screws*

TFE Coated Lead Screws for applications that require a *greaseless* screw and nut interface.

A *dry* (non-lubricated) TFE coated lead screw provides improved performance in both life and thrust as compared to a conventional stainless steel lead-screw. TFE can be applied to a wide variety of lead-screw pitches and is available for our brand captive, non-captive and external linear actuators. Not available for 0.00006-in (.0015 mm) and 0.000098-in (.0025 mm) resolutions.

*Certain conditions apply.

Integrated Anti-Backlash Nut for Hybrids*

Most sizes (except Size 34) of our captive and non-captive hybrid stepper motors can be equipped with an integral anti-backlash feature. There is a normal backlash between the lead screw and integral rotor nut.

Our actuators are designed for millions of cycles. However over time, additional backlash could increase and eventually double. Haydon Kerk Integrated Anti-Backlash Nut can eliminate all backlash. Designed specifically for our captive and non-captive hybrid motors, nuts use an opposing spring force to eliminate backlash between the screw and the nut interface. The nuts will self-compensate and accommodate any wear. Haydon Kerk Motion Solutions application engineers can help you select the appropriate preload for your application.

*Except Size 34.