

Haydon[®] 35000 Series Size 14 hybrid linear actuators have been improved to provide higher force, longer life and improved performance.

The various designs deliver exceptional performance and new linear motion design opportunities. Three designs are available, captive, non-captive and external linear versions. The 35000 Series is available in a wide variety of resolutions - from 0.00012-in (.003048 mm) per step to 0.00192-in (.048768 mm) per step. The motors can also be micro-stepped for even finer resolutions. The Size 14 actuator delivers thrust of up to 50 lbs. (222 N).



Specifications

Size 14: 35 mm (1.4-in) Hybrid Linear Actuator (1.8° Step Angle)						Linear Travel / Step			
Part No.	Captive	Screw Ø .218" (5.54 mm)			Screw Ø .250" (6.35 mm)		Order Code I.D.	Order Code I.D.	Order Code I.D.
		Order Code I.D.	Order Code I.D.	Order Code I.D.	Order Code I.D.				
	Non-captive	35H4	35H6						
	External Lin.	35F4	35F6						
		E35H4	E35H6						
Wiring		Bipolar			Unipolar**				
Winding Voltage		2.33 VDC	5 VDC	12 VDC	5 VDC	12 VDC			
Current (RMS)/phase		1.25 A	0.57 A	0.24 A	0.57 A	0.24 A			
Resistance/phase		1.86 Ω	8.8 Ω	50.5 Ω	8.8 Ω	50.5 Ω			
Inductance/phase		2.8 mH	13 mH	60 mH	6.5 mH	30 mH			
Power Consumption		5.7 W							
Rotor Inertia		16.0 gcm ²							
Insulation Class		Class B (Class F available)							
Weight		5.7 oz (162 g)							
Insulation Resistance		20 MΩ							

Screw Ø	Order Code	Screw Ø	Order Code
.218" (5.54 mm)	I.D.	.250" (6.35 mm)	I.D.
.00012	.0030* N	.00015625	.0039* P
.00024	.0060* K	.0003125	.0079* A
.00048	.0121* J	.000625	.0158* B
.00096	.0243* Q	.00125	.0317* C
.00192	.0487* R		

*Values truncated

Standard motors are Class B rated for maximum temperature of 130°C.

Special drive considerations may be necessary when leaving shaft fully extended or fully retracted.

† Part numbering information on page 5

** Unipolar drive gives approximately 30% less thrust than bipolar drive.

Captive Lead-screw

Dimensions = (mm) inches

Integrated connector option available

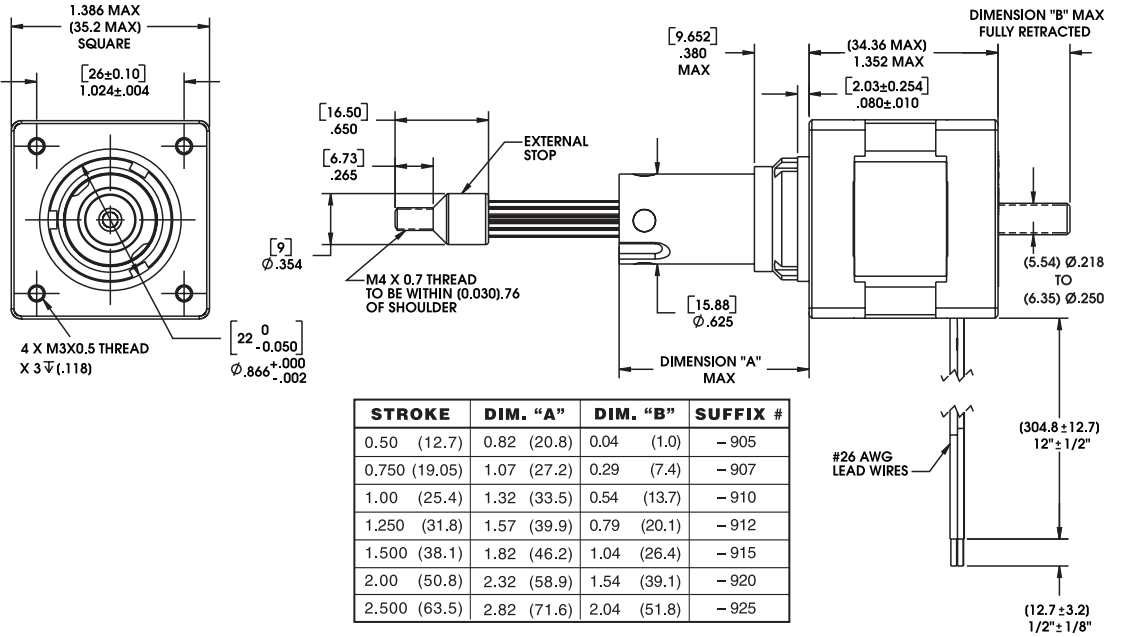

Non-Captive Lead-screw

Dimensions = (mm) inches

Up to 10-in (254 mm) standard screw lengths. Longer screw lengths are available.

Integrated connector option available

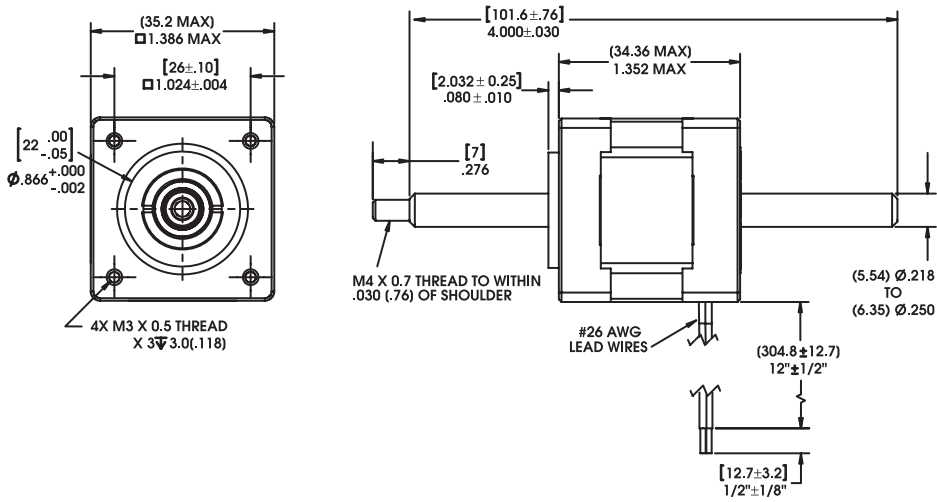

External Linear

Dimensions = (mm) inches

Up to 10-in (254 mm) standard screw lengths. Longer screw lengths are available.

Integrated connector option available

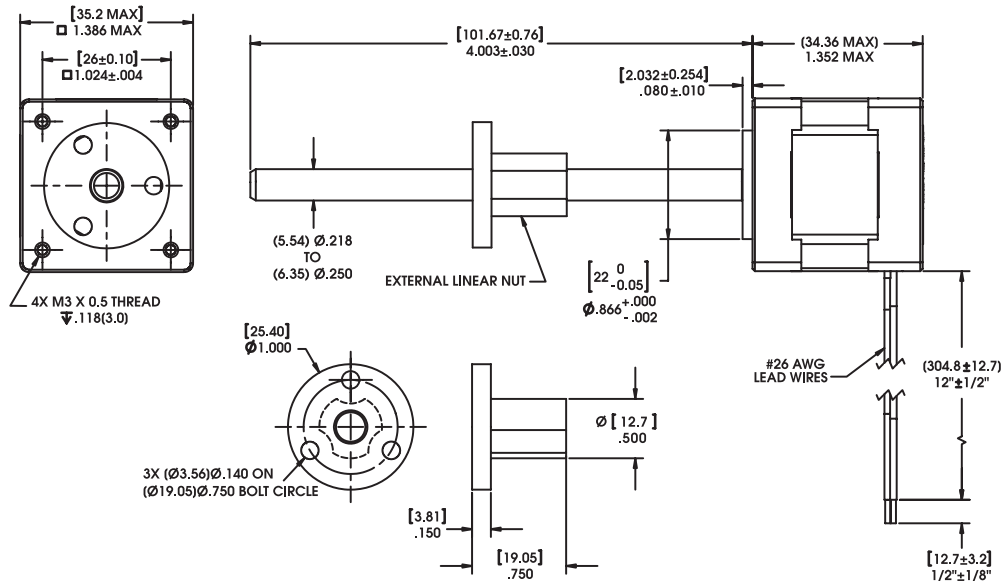

FORCE vs. PULSE RATE

Chopper

Bipolar

100% Duty Cycle

Ø .218 (5.54) Lead-screw >

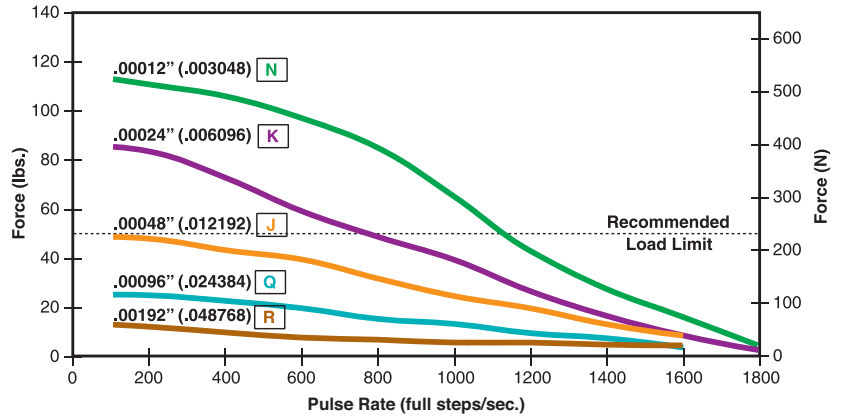

Ø .250 (6.35) Lead-screw >

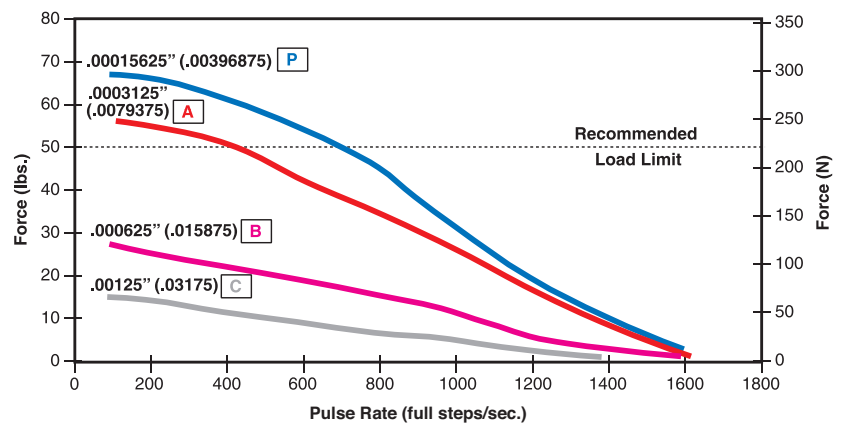

FORCE vs. LINEAR VELOCITY

Chopper Drive

Bipolar

100% Duty Cycle

Ø .218 (5.54) Lead-screw >

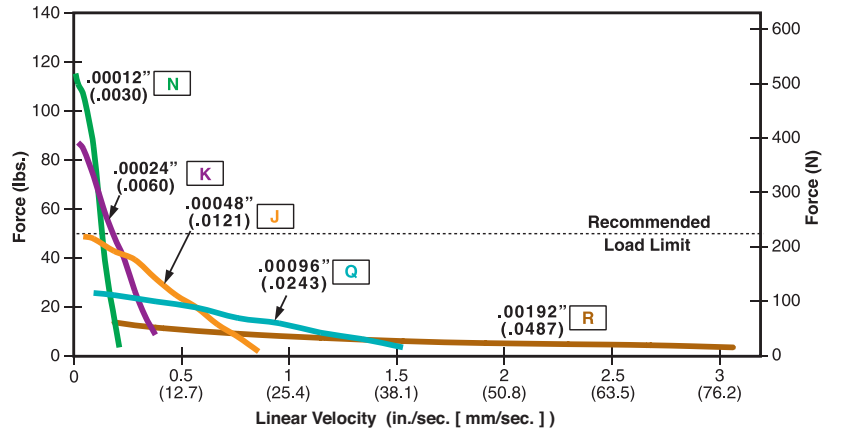

Ø .250 (6.35) Lead-screw >

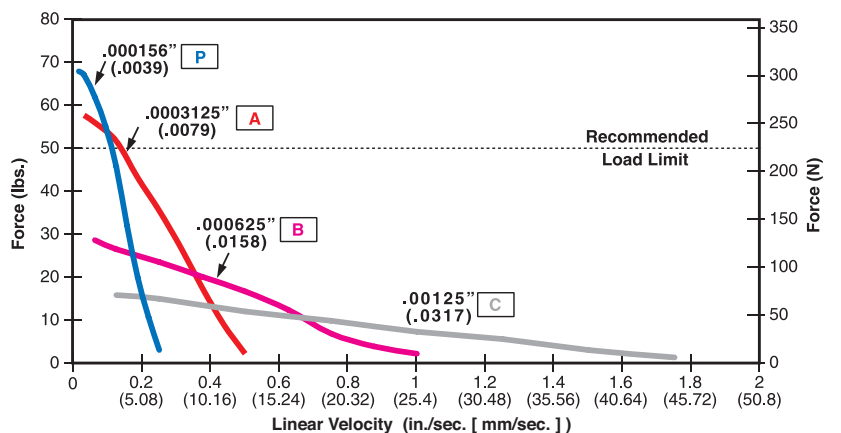

NOTE: All chopper drive curves were created with a 5 volt motor and a 40 volt power supply.

Ramping can increase the performance of a motor either by increasing the top speed or getting a heavier load accelerated up to speed faster. Also, deceleration can be used to stop the motor without overshoot.

With L/R drives peak force and speeds are reduced, using a unipolar drive will yield a further 30% force reduction.

The Haydon[®] 35000 Series Size 14, 0.9° high resolution motor

Compared to the standard resolution (1.8°) this motor has been engineered to precisely deliver reliable high speed, force, up to 50 lbs (222 N), as well as a full step movement as low as 1.5 microns.

Specifications

Size 14: 35 mm (1.4-in) Hybrid Linear Actuator (0.9° Step Angle)					Linear Travel / Step							
Part No.	Captive	35K4 - - - - - †			35K6 - - - - - †		Screw Ø	Order Code	Screw Ø	Order Code		
		35J4 - - - - - †			35J6 - - - - - †		.218" (5.54 mm)	I.D.	.250" (6.35 mm)	I.D.		
	Non-captive	E35K4 - - - - - †			E35K6 - - - - - †		.00006	.0015*	U	.000078*	.00198*	V
	External Lin.						.00012	.0030*	N	.00015625	.0039*	P
							.00024	.0060*	K	.0003125	.0079*	A
							.00048	.0121*	J	.000625	.0158*	B
							.00096	.0243*	Q			
Wiring		Bipolar			Unipolar**							
Winding Voltage		2.33 VDC	5 VDC	12 VDC	5 VDC	12 VDC						
Current (RMS)/phase		1.25 A	0.57 A	0.24 A	0.57 A	0.24 A						
Resistance/phase		1.86 Ω	8.8 Ω	50.5 Ω	8.8	50.5 Ω						
Inductance/phase		2.8 mH	13 mH	60 mH	6.5 mH	30 mH						
Power Consumption		5.7 W										
Rotor Inertia		16 gcm ²										
Insulation Class		Class B (Class F available)										
Weight		5.7 oz (162 g)										
Insulation Resistance		20 MΩ										

*Values truncated
 Special drive considerations may be necessary when leaving shaft fully extended or fully retracted.

NOTE: Refer to performance curves on page 3 for codes N, K, J, Q, P, A, B

† Part numbering information on page 4

** Unipolar drive gives approximately 30% less thrust than bipolar drive.

FORCE vs. PULSE RATE

Chopper Bipolar 100% Duty Cycle

– with two available lead-screw diameters

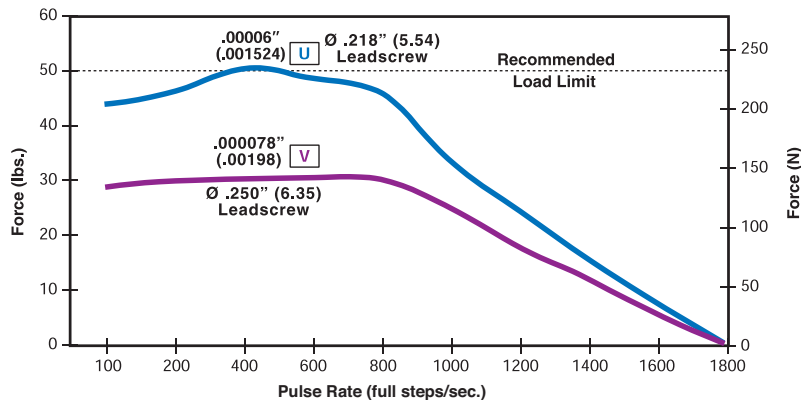

NOTE: All chopper drive curves were created with a 5 volt motor and a 40 volt power supply.

FORCE vs. LINEAR VELOCITY

Chopper Bipolar 100% Duty Cycle

– with two available lead-screw diameters

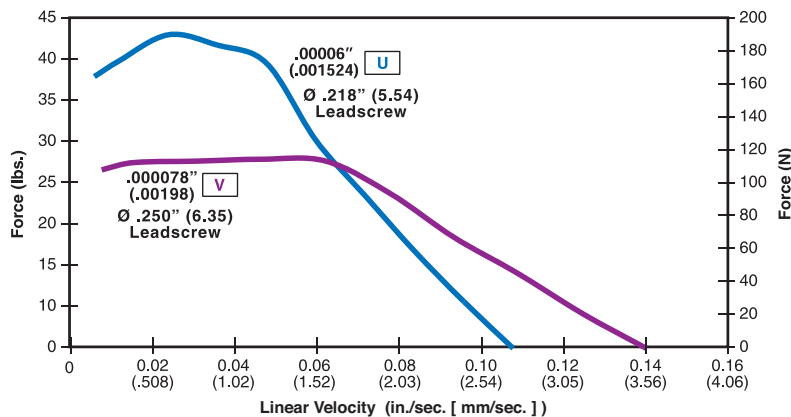

Ramping can increase the performance of a motor either by increasing the top speed or getting a heavier load accelerated up to speed faster. Also, deceleration can be used to stop the motor without overshoot.

With L/R drives peak force and speeds are reduced, using a unipolar drive will yield a further 30% force reduction.

Identifying the Hybrid part number codes when ordering



Prefix
 (include only when using the following)

- A** = A Coil (See AC Synchronous Data Sheet)
- E** = External
- K** = External with 40° thread form
- P** = Proximity Sensor
- S** = Home Switch

Series number designation
35 = 35000

(Series numbers represent approximate width of motor body)

Style

- F** = 1.8° Non-captive
- H** = 1.8° Captive or External (use "E" or "K" Prefix for External version)
- J** = 0.9° Non-captive
- K** = 0.9° Captive or External (use "E" or "K" Prefix for External version)

Coils

- 4** = Bipolar (4 wire)
- 6** = Unipolar (6 wire)

Code ID Resolution Travel/Step

- N** = .00012-in (.0030)
- K** = .00024-in (.0060)
- J** = .00048-in (.0121)
- Q** = .00096-in (.0243)
- P** = .0015625-in (.0039)
- A** = .0003125-in (.0079)
- B** = .000625-in (.0158)
- C** = .00125-in (.0317)
- R** = .00192-in (.0478)

High Resolution

- U** = .00006-in (.0015)
- V** = .000078-in (.00198)

Voltage

- 2.33** = 2.33 VDC
- 05** = 5 VDC
- 12** = 7.5 VDC
- Custom V available

Suffix

Stroke
 Example: -910 = 1-in (Refer to Stroke chart on Captive motor series product page.)

Suffix also represents:

- 800 = Metric
- 900 = External Linear with grease and flanged nut
- XXX = Proprietary suffix assigned to a specific customer application. The identifier can apply to either a standard or custom part.

NOTE: Dashes must be included in Part Number (-) as shown above. For assistance or order entry, call our engineering team at 203 756 7441.

Hybrid Stepper Motor Linear Actuators: OPTIONS

- ENCODERS for all Hybrid Linear Actuator Motors
- OPTIONAL ASSEMBLIES for Hybrid Linear Actuator Motors

Hybrids: Wiring

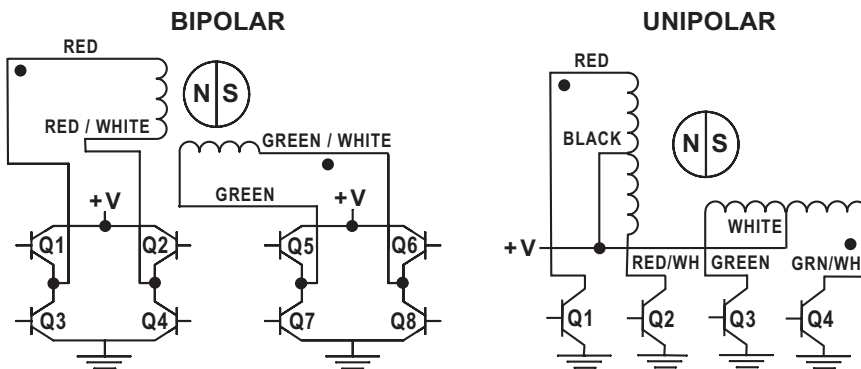

Haydon kerk Express
 Motion Solutions
 Standard products available 24-hrs. at www.haydonkerkexpress.com

Hybrids: Stepping Sequence

	Bipolar	Q2-Q3	Q1-Q4	Q6-Q7	Q5-Q8
Unipolar		Q1	Q2	Q3	Q4
Step					
1		ON	OFF	ON	OFF
2		OFF	ON	ON	OFF
3		OFF	ON	OFF	ON
4		ON	OFF	OFF	ON
1		ON	OFF	ON	OFF

← EXTEND CW RETRACT CCW →

Note: Half stepping is accomplished by inserting an off state between transitioning phases.

Encoders for all sizes of hybrid linear actuators

All Haydon® hybrid linear actuators are available with specifically designed encoders for applications that require feedback. The compact optical incremental encoder design is available with two channel quadrature TTL squarewave outputs. An optional index is also available as a 3rd channel. The Size 14 encoder provides resolutions for applications that require 200, 400 and 1,000 counts per revolution. Encoders are available for all motor configurations – captive, non-captive and external linear.

Simplicity and low cost make the encoders ideal for both high and low volume motion control applications. The internal monolithic electronic module converts the real-time shaft angle, speed, and direction into TTL compatible outputs. The encoder module incorporates a lensed LED light source and monolithic photodetector array with signal shaping electronics to produce the two channel bounceless TTL outputs.



- 2 channel quadrature TTL squarewave outputs.
- Channel B leads A for a clockwise rotation of the rotor viewed from the encoder cover.
- Tracks at speeds of 0 to 100,000 cycles/sec.
- Optional index available as a 3rd channel (one pulse per revolution).

Resolution
 4 standard Cycles Per Revolution
 (CPR) or Pulses Per Revolution (PPR)
Size 14 Encoder

CPR	200	400	1000*
PPR	800	1600	4000*

*Index Pulse Channel not available.

**Single Ended Encoder Pinout
 Size 14**

Connector Pin #	Description
1	Ground
2	Index (optional)
3	Channel A
4	+5 VDC Power
5	Channel B

Mechanical Specifications

	Maximum
Acceleration	250,000 rad/sec ²
Vibration (5 Hz to 2 kHz)	20 g

30 mm 35000 Series Size 14

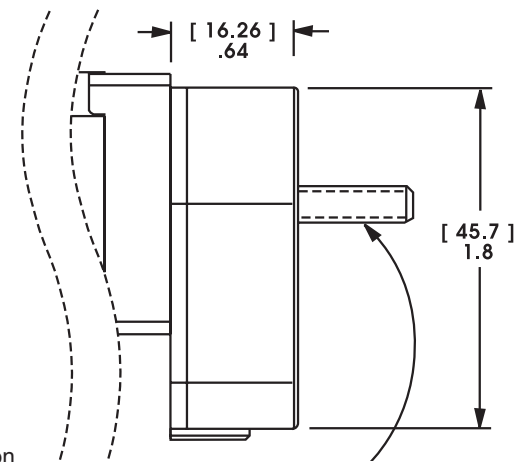

Note: Lead-screw extends beyond encoder on specific captive and non-captive motors. External linear shaft extension is available upon request.

**Differential Ended Encoder
 Pinout
 Size 14**

Connector Pin #	Description
1	Ground
2	Ground
3	- Index
4	+ Index
5	Channel A -
6	Channel A +
7	+5 VDC Power
8	+5 VDC Power
9	Channel B -
10	Channel B +

Electrical Specifications

	Minimum	Typical	Maximum	Units
Input voltage	4.5	5.0	5.5	VDC
Output signals	4.5	5.0	5.5	VDC

Operating Temperature Size 14

Minimum	Maximum
- 40°C (- 40°F)	100°C (212°F)

Integrated Connectors

Hybrid Size 14 linear actuators are available with an integrated connector. Offered alone or with a harness assembly, this connector is RoHS compliant and features a positive latch in order for high connection integrity. The connector is rated up to 3 amps and the mating connector will handle a range of wire gauges from 22 to 28. This motor is ideal for those that want to plug in directly to pre-existing harnesses.

Dimensions =
 (mm) inches

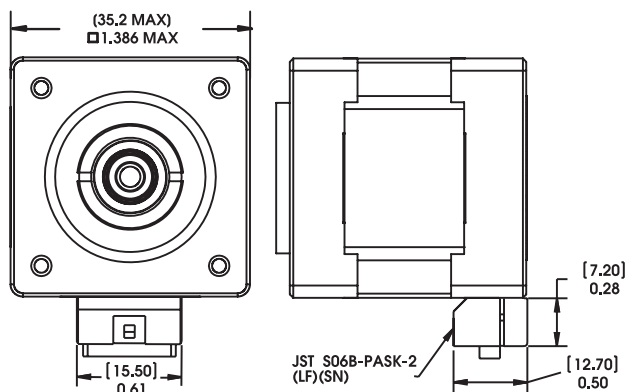

Motor Connector:

JST part # S06B-PASK-2

Mating Connector:

JST part # PAP-06V-S

Haydon Kerk Part #56-1210-5 (12 in. Leads)

Wire to Board Connector:

JST part number SPHD-001T-P0.5

Pin #	Bipolar	Unipolar	Color
1	Phase 2 Start	Phase 2 Start	G/W
2	Open	Phase 2 Common	-
3	Phase 2 Finish	Phase 2 Finish	Green
4	Phase 1 Finish	Phase 1 Finish	R/W
5	Open	Phase 1 Common	-
6	Phase 1 Start	Phase 1 Start	Red



Encoder Ready Option for all sizes of Hybrids

Haydon Hybrid Linear Actuators can now be manufactured as an encoder ready actuator. These encoder ready actuators can be used to install several popular hollow shaft encoders. They are available with an extended rotor journal and a threaded rear housing. The motors use a proprietary manufacturing process which incorporates engineering thermoplastics in the rotor drive nut and a stainless steel Acme lead-screw that allows the motor to be much more efficient and durable than today's more commonly used V-thread/bronze nut configurations.

Extended Rotor Journal for all Hybrid sizes

Haydon Hybrid Linear Actuators are available with an extended rotor journal. This extended rotor journal can be used for encoder installation, manual adjustment, or flag installation for a positioning sensor.

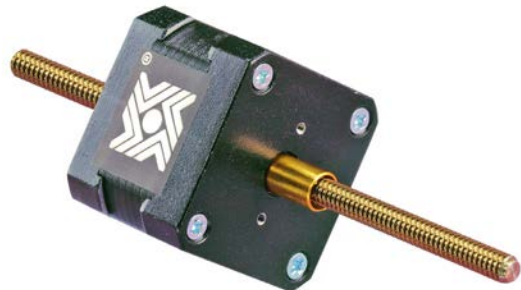

Home Position Switch for Hybrids

A miniature electronic home position switch capable of monitoring the home positions of linear actuators. The switch mounts on the rear sleeve of captive linear motors and allows the user to identify start, stop or home positions. When ordering motors with the home position switch, the part number should be preceded by an "S" prefix.

End of Stroke Proximity Sensor for all sizes of Hybrids

The sensor incorporates a hall effect device, which is activated by a rare earth magnet embedded in the end of the internal screw. The compact profile of the sensor allows for installation in limited space applications.

The sensor has virtually unlimited cycle life. Special cabling and connectors can also be provided. When ordering motors with the proximity sensor, the part number should be preceded by a "P" prefix.



Black Ice[®] and Kerkote[®] TFE Coated Lead-screws (certain conditions apply)

Where applications require the use of a "greaseless" screw and nut interface Haydon Kerk Motion Solutions offers TFE coated lead-screws.

A "dry" (non-lubricated) TFE coated lead-screw provides improved performance in both life and thrust as compared to a conventional stainless steel lead-screw. TFE can be applied to a wide variety of lead-screw pitches and is available for Haydon[®] brand captive, non-captive and external linear linear actuators.



Integrated Anti-backlash Nut for Hybrids

All sizes (except Size 34) of captive and non-captive hybrid stepper motors can be equipped with an integral anti-backlash feature.

There is a normal backlash between the lead screw and integral rotor nut. Haydon[®] actuators are designed for millions of cycles. However, over time additional backlash could increase and eventually double. Haydon Kerk Motion Solutions Integrated Anti-backlash nut can eliminate all backlash. Designed specifically for the Haydon captive and non-captive hybrid motors, these nuts use an opposing spring force to eliminate backlash between the screw and the nut interface. The nuts will self-compensate and accommodate any wear.

Haydon Kerk Motion Solutions application engineers can help you select the appropriate preload for your application.

