

Haydon® Size 11 Double Stack hybrid linear actuators for enhanced performance in motion control

Three designs are available, captive, non-captive and external linear versions. The 28000 Series is available in a wide variety of resolutions - from 0.000125" (.003175 mm) per step to 0.002" (.0508 mm) per step. The Size 11 actuator delivers thrust of up to 30 lbs. (133 N).

Size 11 Double Stack External Linear



Size 11 Double Stack Non-Captive Shaft



Size 11 Double Stack Captive Shaft

Specifications

Size 11: 28 mm (1.1-in) Double Stack Hybrid Linear Actuator (1.8° Step Angle)			
Part No.	Captive	28M4 ■ - ■ - ■ - ■ †	
	Non-captive	28L4 ■ - ■ - ■ - ■ †	
	External Lin.	E28M4 ■ - ■ - ■ - ■ †	
Wiring		Bipolar	
Winding Voltage	2.1 VDC	5 VDC	12 VDC
Current (RMS)/phase	1.9 A	750 mA	313 mA
Resistance/phase	1.1 Ω	6.7 Ω	34.8 Ω
Inductance/phase	1.1 mH	5.8 mH	35.6 mH
Power Consumption	7.5 W Total		
Rotor Inertia	13.5 gcm ²		
Insulation Class	Class B (Class F available)		
Weight	5.8 oz (180 g)		
Insulation Resistance	20 MΩ		

Linear Travel / Step		Order Code I.D.
Screw Ø.1875"(4.76mm) inches	mm	
.000125	.0031*	7
.00025	.0063*	9
.0005	.0127	3
.001	.0254	1
.002	.0508	2

*Values truncated

Standard motors are Class B rated for maximum temperature of 130°C.

Special drive considerations may be necessary when leaving shaft fully extended or fully retracted.

† Part numbering information on page 4

**Captive
 Lead-screw**

Dimensions = (mm) inches

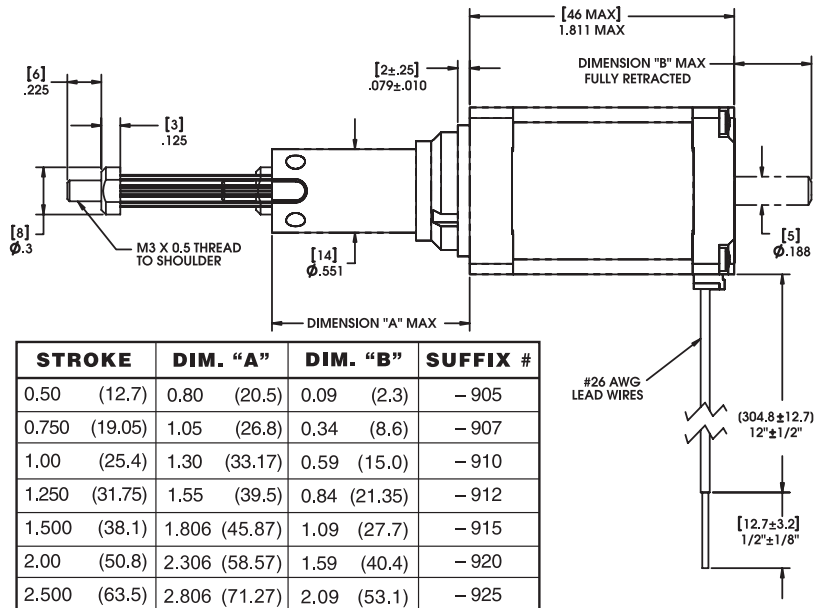
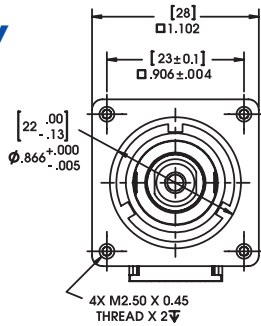

STROKE	DIM. "A"	DIM. "B"	SUFFIX #
0.50 (12.7)	0.80 (20.5)	0.09 (2.3)	- 905
0.750 (19.05)	1.05 (26.8)	0.34 (8.6)	- 907
1.00 (25.4)	1.30 (33.17)	0.59 (15.0)	- 910
1.250 (31.75)	1.55 (39.5)	0.84 (21.35)	- 912
1.500 (38.1)	1.806 (45.87)	1.09 (27.7)	- 915
2.00 (50.8)	2.306 (58.57)	1.59 (40.4)	- 920
2.500 (63.5)	2.806 (71.27)	2.09 (53.1)	- 925

Integrated connector option available

Non-Captive Lead-screw

Dimensions = (mm) inches

Up to 6 in (152 mm) standard screw lengths. Longer screw lengths are available.

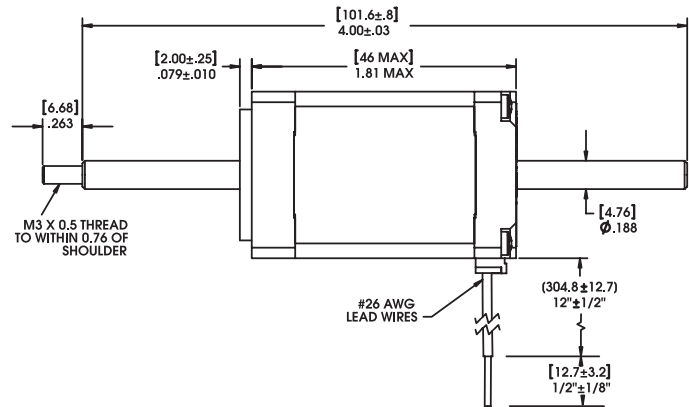
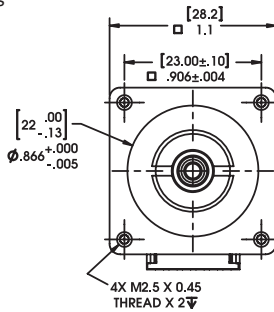

Integrated connector option available

External Linear

Dimensions = (mm) inches

Up to 6-in (152 mm) standard screw lengths. Longer screw lengths are available.

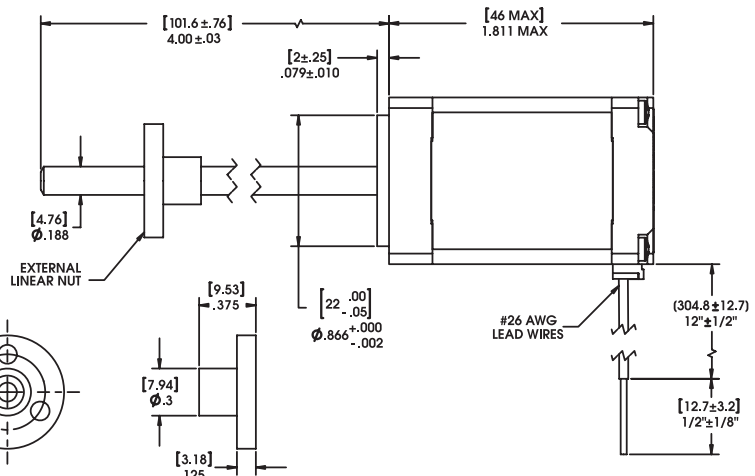
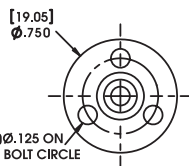
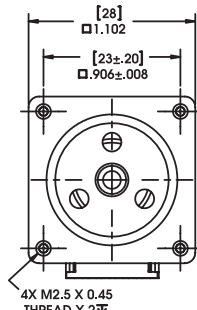

Integrated connector option available

FORCE vs. PULSE RATE

Chopper • Bipolar • 100% Duty Cycle • Ø .1875 (4.75) Lead-screw

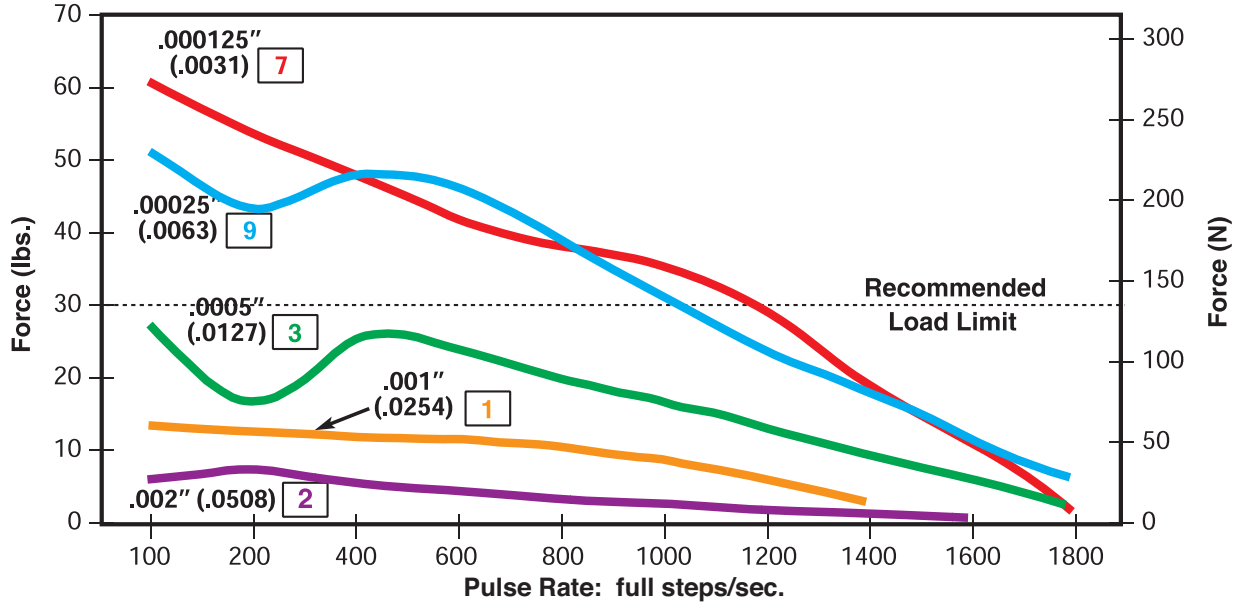

FORCE vs. LINEAR VELOCITY

Chopper • Bipolar • 100% Duty Cycle • Ø .1875 (4.75) Lead-screw

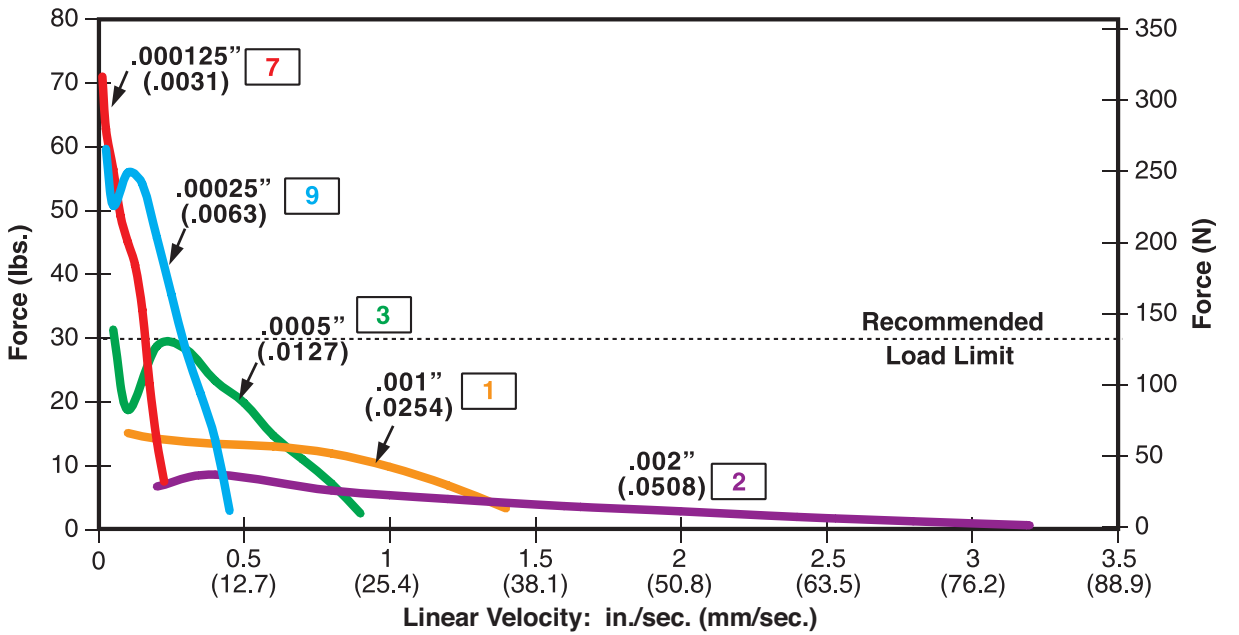

NOTE: All chopper drive curves were created with a 5 volt motor and a 40 volt power supply.

Ramping can increase the performance of a motor either by increasing the top speed or getting a heavier load accelerated up to speed faster. Also, deceleration can be used to stop the motor without overshoot.

With L/R drives peak force and speeds are reduced, using a unipolar drive will yield a further 30% force reduction.

Identifying the Hybrid part number codes when ordering

E	28	M	4	7	-	05	-	910
Prefix (include only when using the following) A = A Coil (See AC Synchronous Data Sheet) E = External K = External with 40° thread form P = Proximity Sensor S = Home Switch	Series number designation 28 = 28000 (Series numbers represent approximate width of motor body)	Style L = 1.8° Non-captive M = 1.8° Captive or External (use "E" or "K" Prefix for External version)	Coils 4 = Bipolar (4 wire)	Code ID Resolution Travel/Step 1 = .001-in (.0254) 2 = .002-in (.0508) 3 = .0005-in (.0127) 7 = .000125-in (.0031) 9 = .00025-in (.0063)		Voltage 2.1 = 2.1 VDC 05 = 5 VDC 12 = 7.5 VDC <i>Custom V available</i>		Suffix Stroke <i>Example: -910 = 1-in (Refer to Stroke chart on Captive motor series product page.)</i> Suffix also represents: -800 = Metric -900 = External Linear with grease and flanged nut -XXX = Proprietary suffix assigned to a specific customer application. The identifier can apply to either a standard or custom part.

NOTE: Dashes must be included in Part Number (-) as shown above. For assistance or order entry, call our engineering team at 203 756 7441.

Hybrids: Wiring

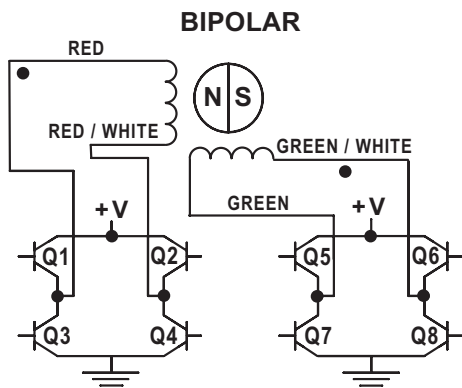

Hybrid Stepper Motor Linear Actuators: OPTIONS

- ENCODERS for all Hybrid Linear Actuator Motors
- OPTIONAL ASSEMBLIES for Hybrid Linear Actuator Motors

Standard products available 24-hrs. at www.haydonkerkexpress.com

Hybrids: Stepping Sequence

	Bipolar	Q2-Q3	Q1-Q4	Q6-Q7	Q5-Q8	
	Step					
EXTEND CW →	1	ON	OFF	ON	OFF	RETRACT CCW ↑
	2	OFF	ON	ON	OFF	
	3	OFF	ON	OFF	ON	
	4	ON	OFF	OFF	ON	
	1	ON	OFF	ON	OFF	

Note: Half stepping is accomplished by inserting an off state between transitioning phases.

Encoders for all sizes of hybrid linear actuators

All Haydon® hybrid linear actuators are available with specifically designed encoders for applications that require feedback. The compact optical incremental encoder design is available with two channel quadrature TTL squarewave outputs. An optional index is also available as a 3rd channel. The Size 11 encoder provides resolutions for applications that require 200, 400 and 1,000 counts per revolution. Encoders are available for all motor configurations – captive, non-captive and external linear.

Simplicity and low cost make the encoders ideal for both high and low volume motion control applications. The internal monolithic electronic module converts the real-time shaft angle, speed, and direction into TTL compatible outputs. The encoder module incorporates a lensed LED light source and monolithic photodetector array with signal shaping electronics to produce the two channel bounceless TTL outputs.

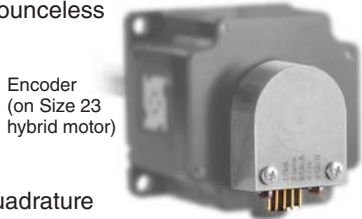

Encoder
 (on Size 23
 hybrid motor)

- 2 channel quadrature TTL squarewave outputs.
- Channel B leads A for a clockwise rotation of the rotor viewed from the encoder cover.
- Tracks at speeds of 0 to 100,000 cycles/sec.
- Optional index available as a 3rd channel (one pulse per revolution).

Electrical Specifications

	Minimum	Typical	Maximum	Units
Input voltage	4.5	5.0	5.5	VDC
Output signals	4.5	5.0	5.5	VDC

Operating Temperature Size 11

Minimum	Maximum
- 40°C (- 40°F)	100°C (212°F)

Resolution

4 standard Cycles Per Revolution (CPR) or Pulses Per Revolution (PPR)

Size 11 Encoder

CPR	200	400	1000*
PPR	800	1600	4000*

*Index Pulse Channel not available.

**Single Ended Encoder Pinout
 Size 11**

Connector Pin #	Description
1	Ground
2	Index (optional)
3	Channel A
4	+5 VDC Power
5	Channel B

Mechanical Specifications

	Maximum
Acceleration	250,000 rad/sec ²
Vibration (5 Hz to 2 kHz)	20 g

30 mm 28000 Series Size 11

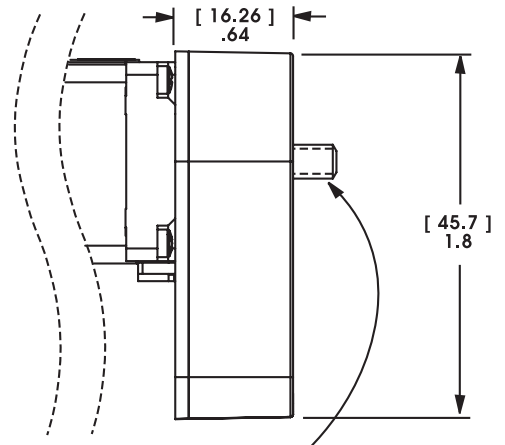

Note: Lead-screw extends beyond encoder on specific captive and non-captive motors. External linear shaft extension is available upon request.

**Differential Ended Encoder
 Pinout
 Size 11**

Connector Pin #	Description
1	Ground
2	Ground
3	- Index
4	+ Index
5	Channel A -
6	Channel A +
7	+5 VDC Power
8	+5 VDC Power
9	Channel B -
10	Channel B +

Integrated Connectors

Hybrid Size 11 linear actuators are available with an integrated connector. Offered alone or with a harness assembly, this connector is RoHS compliant and features a positive latch in order for high connection integrity. The connector is rated up to 3 amps and the mating connector will handle a range of wire gauges from 22 to 28. This motor is ideal for those that want to plug in directly to pre-existing harnesses.

Dimensions =
 (mm) inches

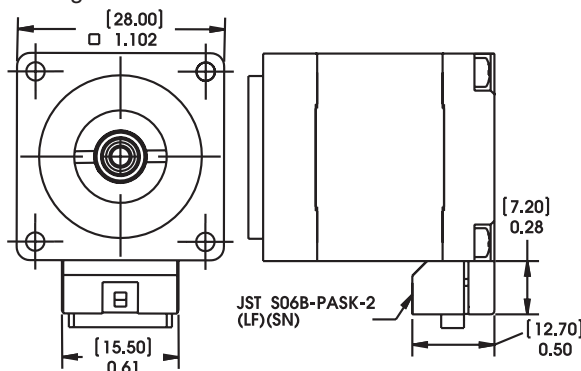

Motor Connector:

JST part # S06B-PASK-2

Mating Connector:

JST part # PAP-06V-S

Haydon Kerk Part #56-1210-5 (12 in. Leads)

Wire to Board Connector:

JST part number SPHD-001T-P0.5

Pin #	Bipolar	Unipolar	Color
1	Phase 2 Start	Phase 2 Start	G/W
2	Open	Phase 2 Common	-
3	Phase 2 Finish	Phase 2 Finish	Green
4	Phase 1 Finish	Phase 1 Finish	R/W
5	Open	Phase 1 Common	-
6	Phase 1 Start	Phase 1 Start	Red



Encoder Ready Option for all sizes of Hybrids

Haydon Hybrid Linear Actuators can now be manufactured as an encoder ready actuator. These encoder ready actuators can be used to install several popular hollow shaft encoders. They are available with an extended rotor journal and a threaded rear housing. The motors use a proprietary manufacturing process which incorporates engineering thermoplastics in the rotor drive nut and a stainless steel Acme lead-screw that allows the motor to be much more efficient and durable than today's more commonly used V-thread/bronze nut configurations.

Extended Rotor Journal for all Hybrid sizes

Haydon Hybrid Linear Actuators are available with an extended rotor journal. This extended rotor journal can be used for encoder installation, manual adjustment, or flag installation for a positioning sensor.



Home Position Switch for Hybrids

A miniature electronic home position switch capable of monitoring the home positions of linear actuators. The switch mounts on the rear sleeve of captive linear motors and allows the user to identify start, stop or home positions. When ordering motors with the home position switch, the part number should be preceded by an "S" prefix.

End of Stroke Proximity Sensor for all sizes of Hybrids

The sensor incorporates a hall effect device, which is activated by a rare earth magnet embedded in the end of the internal screw. The compact profile of the sensor allows for installation in limited space applications.

The sensor has virtually unlimited cycle life. Special cabling and connectors can also be provided. When ordering motors with the proximity sensor, the part number should be preceded by a "P" prefix.



Black Ice[®] and Kerkote[®] TFE Coated Lead-screws (certain conditions apply)

Where applications require the use of a "greaseless" screw and nut interface Haydon Kerk Motion Solutions offers TFE coated lead-screws.

A "dry" (non-lubricated) TFE coated lead-screw provides improved performance in both life and thrust as compared to a conventional stainless steel lead-screw. TFE can be applied to a wide variety of lead-screw pitches and is available for Haydon[®] brand captive, non-captive and external linear linear actuators.

Integrated Anti-backlash Nut for Hybrids

All sizes (except Size 34) of captive and non-captive hybrid stepper motors can be equipped with an integral anti-backlash feature.

There is a normal backlash between the lead screw and integral rotor nut. Haydon[®] actuators are designed for millions of cycles. However, over time additional backlash could increase and eventually double. Haydon Kerk Motion Solutions Integrated Anti-backlash nut can eliminate all backlash. Designed specifically for the Haydon captive and non-captive hybrid motors, these nuts use an opposing spring force to eliminate backlash between the screw and the nut interface. The nuts will self-compensate and accommodate any wear.

Haydon Kerk Motion Solutions application engineers can help you select the appropriate preload for your application.

