

Basic PRO Software Manual



September 2011 (Ver. 1.0)

Motor Power Company s.r.l.

Via Leonardo Da Vinci, 4
42024 Castelnuovo Sotto Reggio Emilia - Italia
Tel. +39 0522 682710 - Fax +39 0522 683552
info@motorpowerco.it - motorpowerco.com
Cap. Soc. 50.960,00 i.v. - R.E.A. di RE 175521
Iscr.Reg.Impr. di RE n.01308390358 - N. Mecc. RE 010210
C.F. e P.IVA IT 01308390358

**MOTOR
POWER**
COMPANY

Notice:

- This guide is delivered subject to the following conditions and restrictions: This guide contains proprietary information belonging to Motor power Company Srl. Such information is supplied solely for the purpose of assisting users of the Basic Pro (1X 2X) servo drive in its installation and configuration.
- The text and graphics included in this manual are for the purpose of illustration and reference only. The specifications on which they are based are subject to change without notice.
- Motor power Company and the Motor power Company logo are trademarks of Motor power Company Srl.
- Information in this document is subject to change without notice.

Version	Release Date	Status	Change/Remarks
Ver. 1.0	August 2011	Draft	
Ver. 2.0	September 2011	BPRO-SM.pdf	Official Release

Motor Power Company s.r.l.

Via Leonardo Da Vinci, 4
42024 Castelnovo Sotto Reggio Emilia - Italia
Tel. +39 0522 682710 - Fax +39 0522 683552
info@motorpowerco.it - motorpowerco.com
Cap. Soc. 50.960,00 i.v. - R.E.A. di RE 175521
Iscr.Reg.Impr. di RE n.01308390358 - N. Mecc. RE 010210
C.F. e P.IVA IT 01308390358



• Contents

Chapter 1: Introduction	7
1.1 Scope.....	7
1.2 Abbreviations.....	7
Chapter 2: Basic PRO Drive Description.....	7
2.1 Software organization.....	8
Chapter 3: Communication with the Host.....	9
3.1 The RS-232 Protocol (Modbus - RTU).....	9
3.2 Command Supported.....	9
Chapter 4: Memory Organization.....	10
4.1 Layout for standard address.....	10
4.1.1 Parameters.....	10
4.1.2 Inputs.....	11
4.1.3 Outputs.....	11
4.1.4 32 bit Parameters and Variables.....	11
Chapter 5: Generic Parameters	12
5.1 Serial Port Baud Rate.....	12
5.2 CanBus Parameters.....	12
5.2.1 CanBus Address Axis1.....	12
5.2.2 CanBus Address Axis2.....	13
5.2.3 CanBus Network Speed.....	13
5.2.4 PWM Frequency.....	14
5.2.5 Input functionality.....	14
5.2.6 Input Logic.....	16
5.2.7 Output Functionality.....	16
5.2.8 Output Logic.....	17
5.2.9 Scope Variables.....	17
5.2.10 User Program Active.....	18
Chapter 6: Axis Parameters.....	19
6.1 Motor Data.....	19
6.1.1 Motor Poles.....	19
6.1.2 Encoder Pulses per Revolution (PPR).....	19
6.1.3 In Nominal Current.....	20
6.1.4 I _{max} Peak Current.....	20
6.1.5 I _{2T} Time.....	21
6.1.6 Max RPM.....	21
6.1.7 Motor K _t (Torque Constant).....	22
6.2 Modes of operation.....	22
6.3 Controller Loop Parameters.....	23
6.3.1 Current Gains.....	23
6.3.2 Velocity Gains.....	23
6.3.3 Position Gains.....	24
6.3.4 Torque Filter.....	24
6.3.5 Velocity Filter.....	25
6.3.6 Velocity Feed Forward.....	25
6.3.7 Acceleration Feed Forward.....	26
6.4 Analog Input Functionality.....	27
6.4.1 Enable Analog Input.....	27
6.4.2 Analog Safe Zero.....	27
6.4.3 Analog Offset.....	28
6.4.4 Analog Filter.....	28
6.4.5 Analog Input Fault.....	29
6.4.6 Analog Input Polarity.....	29

Motor Power Company s.r.l.

Via Leonardo Da Vinci, 4
42024 Castelnuovo Sotto Reggio Emilia - Italia
Tel. +39 0522 682710 - Fax +39 0522 683552
info@motorpowerco.it - motorpowerco.com
Cap. Soc. 50.960,00 i.v. - R.E.A. di RE 175521
Iscr.Reg.Impr. di RE n.01308390358 - N. Mecc. RE 010210
C.F. e P.IVA IT 01308390358



6.5 Brake Parameters.....	30
6.5.1 Brake TurnOn Delay.....	30
6.5.2 Brake TurnOff Delay.....	30
6.6 Safety Parameters.....	31
6.6.1 Over Velocity.....	31
6.7 Homing Parameters.....	31
6.7.1 Homing Method.....	31
6.7.2 Home Offset.....	33
6.7.3 Homing Speed to Switch.....	33
6.7.4 Homing speed to Index.....	33
6.7.5 Homing Acceleration.....	34
6.7.6 Post homing action.....	34
6.7.7 Post homing Offset.....	35
6.7.8 Post homing speed.....	35
6.7.9 Homing Timeout.....	35
6.7.10 Homing Current Comparison.....	36
6.7.11 Homing I2t Threshold Value.....	36
6.7.12 Homing Current Threshold Value.....	37
6.7.13 Homing Current Threshold Time.....	37
6.8 Profile Parameters.....	38
6.8.1 Profile Mode.....	38
6.8.2 Interp Max Vel.....	38
6.8.3 Acceleration.....	39
6.8.4 Deceleration.....	39
6.8.5 Stop Deceleration.....	39
6.8.6 Velocity Radius.....	40
6.8.7 Velocity Radius Time.....	40
6.8.8 Velocity Threshold.....	41
6.8.9 Velocity Threshold Time.....	41
6.8.10 Velocity Error Radius.....	41
6.8.11 Velocity Error Radius Time	42
6.8.12 Position Radius.....	42
6.8.13 Position Radius Time.....	42
6.8.14 Following Error Window.....	43
6.8.15 Following Error Timeout.....	43
6.8.16 Polarity.....	44
6.8.17 Software Position Limits.....	45
6.9 Control Loop Tuning Parameters.....	46
6.9.1 Current Tuning Freq.....	46
6.9.2 Current Tuning Delay.....	47
6.9.3 Current Tuning DutyCycle.....	47
6.10 Static PDO Mapping Parameters.....	47
6.11 Status Word Masking.....	48
6.12 Boot NMT Status.....	48
6.13 Static PDO Mapping.....	49
6.14 Torque Limits.....	50
6.14.1 Positive Torque Limit.....	50
6.14.2 Negative Torque Limit.....	51
6.15 JOG Parameters	51
6.15.1 JOG Positive.....	51
6.15.2 JOG Negative Axis.....	52
Chapter 7: Generic Inputs.....	53
7.1 Save To Flash.....	53
7.2 Set Default Parameters.....	54
7.3 Reset Drive.....	54
7.4 Start Bootloader.....	55
7.5 Force Output.....	55

7.6 Password	56
Chapter 8: Axis Inputs.....	57
8.1 Control Word.....	57
8.1.1 Enable.....	57
8.1.2 Begin.....	58
8.1.3 Fault Reset.....	58
8.1.4 Halt.....	59
8.1.5 Set immediately.....	59
8.1.6 Use Relative Position.....	59
8.2 Targets.....	60
8.2.1 Current Target.....	60
8.2.2 Speed Target.....	60
8.2.3 Position Target.....	61
Chapter 9: Generic Outputs.....	61
9.1 Firmware Version.....	61
9.2 Flash Status.....	62
9.3 DC Bus Voltage.....	63
9.4 DC Bus Offset.....	63
9.5 Input bits.....	63
9.6 Output bits.....	64
9.7 Can Bus Outputs.....	64
9.7.1 Vendor ID.....	64
9.7.2 Product Code.....	65
9.7.3 Revision Number.....	65
9.7.4 Serial Number.....	66
9.7.5 Can Tx Error Counter.....	66
9.7.6 Can Rx Error Counter.....	66
9.7.7 CAN Status Register.....	67
9.7.8 CAN Error Register.....	67
Chapter 10: Axis Outputs.....	67
10.1 Status Word.....	68
10.2 Fault Register.....	68
10.3 Control Mode Display.....	69
10.4 Analog Input.....	69
10.5 Hall Signals Value.....	70
10.6 Current Output.....	70
10.6.1 Iq Target.....	70
10.6.2 Actual Iq.....	71
10.6.3 Iq Error.....	71
10.6.4 Iq Demand.....	71
10.6.5 Iq Tracking Error.....	72
10.7 Velocity Outputs.....	72
10.7.1 Velocity Target.....	72
10.7.2 Actual Velocity.....	73
10.7.3 Velocity Error.....	73
10.7.4 Velocity Demand.....	73
10.7.5 Velocity Tracking Error.....	74
10.8 Position Outputs.....	74
10.8.1 Position Target.....	74
10.8.2 Actual Position.....	75
10.8.3 Position Error.....	75
10.8.4 Position Demand.....	76
10.8.5 Position Tracking Error.....	76
10.8.6 In Position.....	76
10.8.7 Interp Ready.....	77
10.9 Homing Status.....	77
10.10 Motor Usage.....	78

Motor Power Company s.r.l.

Via Leonardo Da Vinci, 4
42024 Castelnuovo Sotto Reggio Emilia - Italia
Tel. +39 0522 682710 - Fax +39 0522 683552
info@motorpowerco.it - motorpowerco.com
Cap. Soc. 50.960,00 i.v. - R.E.A. di RE 175521
Iscr.Reg.Impr. di RE n.01308390358 - N. Mecc. RE 010210
C.F. e P.IVA IT 01308390358



10.11 Axis Enabled.....	78
10.12 Axis Status.....	79
10.13 NMT State.....	79
10.14 Latch Position Output.....	81
10.14.1 Positive Edge Position Latch.....	81
10.14.2 Negative Edge Position Latch.....	81
Chapter 11: The Controller.....	83
11.1 Current Controller.....	83
11.2 Speed Controller	84
11.3 Position Controller.....	85
11.4 The PI controller.....	85

Motor Power Company s.r.l.

Via Leonardo Da Vinci, 4
42024 Castelnuovo Sotto Reggio Emilia - Italia
Tel. +39 0522 682710 - Fax +39 0522 683552
info@motorpowerco.it - motorpowerco.com
Cap. Soc. 50.960,00 i.v. - R.E.A. di RE 175521
Iscr.Reg.Impr. di RE n.01308390358 - N. Mecc. RE 010210
C.F. e P.IVA IT 01308390358



Chapter 1: Introduction

1.1 Scope

This manual describes, in detail, the software used with the Basic Pro line of digital servo drives. It is an integral part of the Basic Pro documentation set, which includes:

Basic Pro – Software Manual

Basic Pro – Installation Guide

Basic Pro – CANOpen Manual

1.2 Abbreviations

The following abbreviations are used in this document:

Chapter 2: Basic PRO Drive Description

Basic Pro drives are, single-axis and multi-axis digital drives, featuring:

- State-of-the-art control algorithms including high-order filters and gain scheduling
- A sophisticated reference generation algorithm, which includes absolute time interpolated motion, auxiliary signal following and ECAM
- Synchronization capability for network operation
- Conformance to CANopen standards
- Advanced analysis tool for setup
- Built-in auto-tuning facilities
- Built-in database maintenance tools
- Built-in firmware maintenance tools

All these features are implemented in the tiny DSP environment.

2.1 Software organization

The internal software is organized into 3 different layers

- (a) Boot loader
- (b) Motion Control Firmware
- (c) Application Software

The Boot Loader is the software who is taking care of the device boot-up. If no firmware is present the bootloader will wait until an new firmware is loaded on the device. The boot loader always ensure a save restore of the device under any condition.

The Motion Control Firmware, is the software that take care of the Device communications RS-232 Modbus and CanOpen, and the implementation of the Motion control Functionality.

The Application software is an additional software that use the Communication and Motion Control functionality of the Device to solve dedicated application. Check <http://www.motorpowergroup.com> for existing advanced functionality.

Motor Power Company s.r.l.

Via Leonardo Da Vinci, 4
42024 Castelnuovo Sotto Reggio Emilia - Italia
Tel. +39 0522 682710 - Fax +39 0522 683552
info@motorpowerco.it - motorpowerco.com
Cap. Soc. 50.960,00 i.v. - R.E.A. di RE 175521
Iscr.Reg.Impr. di RE n.01308390358 - N. Mecc. RE 010210
C.F. e P.IVA IT 01308390358



Chapter 3: Communication with the Host

The Basic PRO drive can operate with RS-232 communication or CANopen communication.

This chapter discusses RS-232 communication. Refer to the Basic PRO CANopen Implementation Manual for detailed information about operation with CANopen networking.

The Basic PRO drive can communicate by RS-232 with baud rates of up to 57,600 baud/s.

3.1 The RS-232 Protocol (Modbus - RTU)

The protocol that is actually running on the RS-232, is the Standard ModBus RTU. For more information on this protocol, please refer to the official website (<http://www.modbus.org/>)

The standard parameter for RS-232 configuration are

Parameter	Value
Speed (baud/s)	57600
Parity	None
Stop Bits	1
Data (bit)	8

The modbus slave address is 247 and actually is a fixed value.

3.2 Command Supported

Actually not all the command implemented in the modbus protocol are available. Here below you can find a list of the supported commands

Command Code	Command Description
3	READ_HOLDING_REGISTERS
6	WRITE_SINGLE_REGISTER
16	WRITE_MULTIPLE_REGISTERS

Motor Power Company s.r.l.

Via Leonardo Da Vinci, 4
42024 Castelnuovo Sotto Reggio Emilia - Italia
Tel. +39 0522 682710 - Fax +39 0522 683552
info@motorpowerco.it - motorpowerco.com
Cap. Soc. 50.960,00 i.v. - R.E.A. di RE 175521
Iscr.Reg.Impr. di RE n.01308390358 - N. Mecc. RE 010210
C.F. e P.IVA IT 01308390358



For more information regarding Modbus protocol, please refer to Modbus official documentation (<http://www.modbus.org/>)

Each Register is the minimum information that you can store into the Basic PRO and it's size is 16 bits (WORD)

Chapter 4: Memory Organization

All the parameters necessary to run the Basic PRO are mapped into the Modbus address. The maximum number of allowable registers are 65.535, actually only a few are used and described in this manual.

4.1 Layout for standard address

The memory of the Basic PRO is organized into 3 different area, Parameters, Input and Outputs.

Address	Length	Memory Area	Saved to Flash	Type
0-511	512	Parameters	YES	RW
512-639	128	Inputs	NO	RW
640-767	128	Outputs	NO	RO

4.1.1 Parameters

The Parameters memory values are used for general, axis1 or axis2 parametrization. All the parameters can be stored into the Serial Flash of the Drive and will be restored at next boot.

Address	Length	Memory Area
0-127	128	Generic Parameters
128-319	192	Axis1 Parameters
320-511	192	Axis1 Parameters

Motor Power Company s.r.l.

Via Leonardo Da Vinci, 4
42024 Castelnuovo Sotto Reggio Emilia - Italia
Tel. +39 0522 682710 - Fax +39 0522 683552
info@motorpowerco.it - motorpowerco.com
Cap. Soc. 50.960,00 i.v. - R.E.A. di RE 175521
Iscr.Reg.Impr. di RE n.01308390358 - N. Mecc. RE 010210
C.F. e P.IVA IT 01308390358



4.1.2 Inputs

This memory area is used to send general, axis1 and axis2 commands to the Servo Drive, like Servo On or Target Position. These values can be read and Written, but not saved on the flash.

Address	Length	Memory Area
512-539	28	Generic Inputs
540-589	50	Axis1 Inputs
590-639	50	Axis2 Inputs

4.1.3 Outputs

This memory area is used to show the general, axis1 or axis2 status of the Basic Pro. All the data present in this memory are updated real time and can be read and shown to the user. This memory is read Only and not saved on the Flash

Address	Length	Memory Area
640-667	28	Generic Outputs
668-717	50	Axis1 Outputs
718-767	50	Axis2 Outputs

4.1.4 32 bit Parameters and Variables

When is necessary to provide the storage to la long (32bit) variable, 2 consecutive memory area of 16bits will be used

Space	Variable
16bit	VARIABLE_LOW_VALUE
16bit	VARIABLE_HIGH_VALUE

Chapter 5: Generic Parameters

In this chapter we will describe all the generic parameters and their functionality

5.1 Serial Port Baud Rate

With this parameter it will be possible to change the RS-232 port baud rate. The change will be activated at next reboot.

Parameter	Serial Port Baud Rate
Address	5
Base Address	0
Access	R/W
Default Values	2
Range	[0-3]
Activation	REBOOT

list of possible configuration

Value	Port Speed (baud/s)
0	57600
1	38400
2	19200
3	9600

5.2 CanBus Parameters

With the following parameters it will be possible to configure the Can Network functionality

5.2.1 CanBus Address Axis1

Parameter	CanBus Address Axis1
Address	8
Base Address	0
Access	R/W
Default Values	1
Range	[1-127]
Activation	REBOOT

5.2.2 CanBus Address Axis2

Parameter	CanBus Address Axis2
Address	9
Base Address	0
Access	R/W
Default Values	2
Range	[1-127]
Activation	REBOOT

5.2.3 CanBus Network Speed

Parameter	CanBus Network Speed
Address	10
Base Address	0
Access	R/W
Default Values	1
Range	[0-7]
Activation	REBOOT

Motor Power Company s.r.l.

Via Leonardo Da Vinci, 4
42024 Castelnuovo Sotto Reggio Emilia - Italia
Tel. +39 0522 682710 - Fax +39 0522 683552
info@motorpowerco.it - motorpowerco.com
Cap. Soc. 50.960,00 i.v. - R.E.A. di RE 175521
Iscr.Reg.Impr. di RE n.01308390358 - N. Mecc. RE 010210
C.F. e P.IVA IT 01308390358



list of possible configuration

Value	Can Port Speed (kb/s)
0	1000
1	500
2	250
3	125
4	100
5	50

5.2.4 PWM Frequency

It's possible to change the PWM frequency

Parameter	Pwm Frequency
Address	3
Base Address	0
Access	R/W
Default Values	5
Range	[4-12]
Activation	REBOOT



Only expert operators have to change this value. This value will change the heating of the system and if increased to much may damage the drive.
If this value will be changed all the gains (Current Loop, Velocity Loop, and Position Loop have to be changed) in order to prevent instability, which may damage the drive and/or the motor.

5.2.5 Input functionality

From parameters 20 to 29 we can find the Input functionality. The Drive have several non committed I/O that the user can program with the functionality he needs.

Parameter	I[n] Input Functionality
Address	20+[n]
Base Address	0
Access	R/W
Default Values	0
Range	[0-100]
Activation	IMMEDIATE

Where [n] = [0-9]

list of possible configuration

Value	Input Functionality
0	General Purpose
1	Positive Limit Switch Axis1
2	Positive Limit Switch Axis2
3	Negative Limit Switch Axis1
4	Negative Limit Switch Axis2
5	Enable Axis1
6	Enable Axis2
7	Start Axis1
8	Start Axis2
9	Emergency Stop Axis1
10	Emergency Stop Axis2
11	Fault Reset Axis1
12	Fault Reset Axis2
13	Fault Reset Axis1&Axis2
14	Enable Axis1 & Axis2
15	Start Axis1 & Axis2
16	Emergency Stop Axis1 & Axis2
17	-
18	Home Switch1
19	Home Switch2
20	Positive Jog Axis1
21	Positive Jog Axis2
22	Negative Jog Axis1
23	Negative Jog Axis2

Motor Power Company s.r.l.

Via Leonardo Da Vinci, 4
42024 Castelnovo Sotto Reggio Emilia - Italia
Tel. +39 0522 682710 - Fax +39 0522 683552
info@motorpowerco.it - motorpowerco.com
Cap. Soc. 50.960,00 i.v. - R.E.A. di RE 175521
Iscr.Reg.Impr. di RE n.01308390358 - N. Mecc. RE 010210
C.F. e P.IVA IT 01308390358



24	Positive Torque Limit Axis1
25	Positive Torque Limit Axis2
26	Negative Torque Limit Axis1
27	Negative Torque Limit Axis2
28	Torque Limit Axis1
29	Torque Limit Axis2
30	Position latch Axis1
31	Position Latch Axis2

5.2.6 Input Logic

These parameters defines the logic level of the digital inputs.

Parameter	I[n] Input Logic
Address	34+[n]
Base Address	0
Access	R/W
Default Values	0
Range	[0-1]
Activation	IMMEDIATE

Where [n] = [0-9]

list of possible values

Value	Input Functionality
0	Negative Logic
1	Positive Logic

Motor Power Company s.r.l.

Via Leonardo Da Vinci, 4
42024 Castelnuovo Sotto Reggio Emilia - Italia
Tel. +39 0522 682710 - Fax +39 0522 683552
info@motorpowerco.it - motorpowerco.com
Cap. Soc. 50.960,00 i.v. - R.E.A. di RE 175521
Iscr.Reg.Impr. di RE n.01308390358 - N. Mecc. RE 010210
C.F. e P.IVA IT 01308390358



5.2.7 Output Functionality

From parameters 30 to 34 we can find the Output functionality. The Drive have several non committed I/O that the user can program with the functionality he needs.

Parameter	O[n] Output Functionality
Address	30+[n]
Base Address	0
Access	R/W
Default Values	0
Range	[0-100]
Activation	IMMEDIATELY

Where [n] = [0-3]

list of possible configuration

Value	Output Functionality
0	General Purpose
1	Brake Axis1 (Use Output4)
2	Brake Axis2 (Use Output4)
3	Drive OK Axis1
4	Drive OK Axis2
5	In Position Axis1
6	In Position Axis2
7	PowerOn Axis1
8	PowerOn Axis2

Motor Power Company s.r.l.

Via Leonardo Da Vinci, 4
42024 Castelnuovo Sotto Reggio Emilia - Italia
Tel. +39 0522 682710 - Fax +39 0522 683552
info@motorpowerco.it - motorpowerco.com
Cap. Soc. 50.960,00 i.v. - R.E.A. di RE 175521
Iscr.Reg.Impr. di RE n.01308390358 - N. Mecc. RE 010210
C.F. e P.IVA IT 01308390358



5.2.8 Output Logic

These parameters defines the logic level of the digital inputs.

Parameter	I[n] Input Logic
Address	44+[n]
Base Address	0
Access	R/W
Default Values	0
Range	[0-1]
Activation	IMMEDIATELY

Where [n] = [0-3]

list of possible values

Value	Input Functionality
0	Negative Logic
1	Positive Logic

5.2.9 Scope Variables

The internal scope configuration can be saved into the serial Flash of the drive for this reason in the Generic Parameter we can find an array of value that define the Scope variables configuration

Parameter	S[n] Scope Configuration
Address	120+[n]
Base Address	0
Access	R/W
Default Values	0
Range	[0-65535]
Activation	IMMEDIATE

Where [n] = [0-7]

The scope configuration is a structure that define which Scope channel will be used and the value saved in this track.

bit	Value
[15-13]	Channel
[12-10]	Reserved
[9-0]	Value

The list of value is available on appendix D of this manual.

5.2.10 User Program Active

This Parameter allow to activate the UserProgram function if present in the Drive Firmware.

Parameter	User Program Active
Address	14
Base Address	0
Access	R/W
Default Values	0
Range	[0-1]
Activation	IMMEDIATE

Chapter 6: Axis Parameters

In this chapter we will describe all the parameters necessary to configure the Drive and the Motor

6.1 Motor Data

Here below are listed all the necessary motor information.

6.1.1 Motor Poles

Parameter	Motor Poles
Address	13
Base Address	Axis1=128 , Axis2=320
Access	R/W
Default Values	8
Range	[2-100]
Activation	REBOOT

Many motor manufacturer declare the Pole Pairs, to enter the right value you must use the following rule:

$$\text{Motor Poles} = 2 * \text{Motor Poles Pair}$$

6.1.2 Encoder Pulses per Revolution (PPR)

This parameter represent the number of pulses of the Encoder mounted on the motor, the final resolution after interpolation will be:

$$\text{Final Resolution} = \text{ppr} * 4$$

Parameter	Encoder PPR
Address	20-21 (32bit)
Base Address	Axis1=128 , Axis2=320
Access	R/W
Default Values	2000
Range	[0 - 4.294.967.296]
Activation	REBOOT

	<p>When you change this parameter, it's important that you Save to Flash and Reboot the device, before running the motor.</p>
---	---

6.1.3 In Nominal Current

The nominal current defines the maximum allowed continuous motor phase current, in amperes Arms. This parameter is used to protect the motor from over-current, and the load from excessive torques. The motor current (torque) command is normally limited to its peak limit, as defined by I_{max} Peak Current.

The nominal current cannot be higher then the nominal current of the Drive.

Parameter	In Nominal Current
Address	14
Base Address	Axis1=128 , Axis2=320
Access	R/W
Default Values	500 mA
Range	[1-20000]
Activation	REBOOT

This value is internally from the drive to it's maximum limits.

6.1.4 I_{max} Peak Current

This parameter is used to protect the motor (or the drive) from over-current, and to

protect the load from excessive torque. It's possible to use peak current for a time of I2T Time, after that time we will get an Overload Error.

Parameter	In Nominal Current
Address	15
Base Address	Axis1=128 , Axis2=320
Access	R/W
Default Values	1000 mA
Range	[1-35000]
Activation	IMMEDIATE

This value is internally from the drive to it's maximum limits.

6.1.5 I2T Time

This parameter define for how much time is possible to use the Peak current. This value will affect the Motor Usage Output Variable.

Parameter	In Nominal Current
Address	17
Base Address	Axis1=128 , Axis2=320
Access	R/W
Default Values	2500 s
Range	[0-2500]
Activation	IMMEDIATE

6.1.6 Max Motor Velocity

Represent the maximum velocity of the motor represented in User Units. All the internal calculation of the drive use this value as a reference. In order to optimize your system please set this parameter close to your application requirement.

Parameter	Max Motor Velocity
Address	20-21 (32bit)
Base Address	Axis1=128 , Axis2=320

Access	R/W
Default Values	3000 [User Units]
Range	[0 - 4.294.967.296]
Activation	IMMEDIATE

6.1.7 Motor Kt (Torque Constant)

This parameter is useful to show Torque demand value instead of current values on the controller.

Parameter	Kt
Address	16
Base Address	Axis1=128 , Axis2=320
Access	R/W
Default Values	100 [1/100 Nm/Arms]
Range	[0 - 65535]
Activation	IMMEDIATE

6.2 Modes of operation

The servo drive can operate in different mode. It's configuration is a parameter because we need that the servo will start in the preferred mode at next boot up.

Parameter	Mode of Operation
Address	0
Base Address	Axis1=128 , Axis2=320
Access	R/W
Default Values	3
Range	[-4 7]
Activation	IMMEDIATE

Actually the following modes of operation are supported:

Value	Mode of operation
-4	Tuning Current Loop
-3	Tuning Velocity Loop
-1	Tuning Position Loop
1	Position Profile Mode
3	Velocity Mode
4	Current Mode
6	Homing Mode
7	Interpolated Position Mode

6.3 Controller Loop Parameters

6.3.1 Current Gains

Proportional Gain of current Loop

Parameter	KP Current
Address	6
Base Address	Axis1=128 , Axis2=320
Access	R/W
Default Values	400
Range	[0-65535]
Activation	IMMEDIATE

Integral Gain of current Loop

Parameter	KI Current
Address	7
Base Address	Axis1=128 , Axis2=320
Access	R/W
Default Values	500
Range	[0-65535]
Activation	IMMEDIATE

Motor Power Company s.r.l.

Via Leonardo Da Vinci, 4
42024 Castelnovo Sotto Reggio Emilia - Italia
Tel. +39 0522 682710 - Fax +39 0522 683552
info@motorpowerco.it - motorpowerco.com
Cap. Soc. 50.960,00 i.v. - R.E.A. di RE 175521
Iscr.Reg.Impr. di RE n.01308390358 - N. Mecc. RE 010210
C.F. e P.IVA IT 01308390358



6.3.2 Velocity Gains

Proportional Gain of velocity Loop

Parameter	KP Velocity
Address	8
Base Address	Axis1=128 , Axis2=320
Access	R/W
Default Values	400
Range	[0-65535]
Activation	IMMEDIATE

Integral Gain of velocity Loop

Parameter	KI Velocity
Address	9
Base Address	Axis1=128 , Axis2=320
Access	R/W
Default Values	500
Range	[0-65535]
Activation	IMMEDIATE

6.3.3 Position Gains

Proportional Gain of position Loop

Parameter	KP Position
Address	10
Base Address	Axis1=128 , Axis2=320
Access	R/W
Default Values	1000
Range	[0-65535]
Activation	IMMEDIATE

6.3.4 Torque Filter

This parameter allow to introduce a low pass filter in the current control loop. The parameter specify the cut-off frequency. If the parameter in 0 the filter is disabled.

Parameter	Torque filter
Address	73
Base Address	Axis1=128 , Axis2=320
Access	R/W
Default Values	0 [Hz]
Range	[0-10.000]
Activation	IMMEDIATE

6.3.5 Velocity Filter

This parameter allow to introduce a low pass filter in the velocity control loop. The parameter specify the cut-off frequency. If the parameter in 0 the filter is disabled.

Parameter	Velocity filter
Address	72
Base Address	Axis1=128 , Axis2=320
Access	R/W
Default Values	0 [Hz]
Range	[0-10.000]
Activation	IMMEDIATE

Motor Power Company s.r.l.

Via Leonardo Da Vinci, 4
42024 Castelnuovo Sotto Reggio Emilia - Italia
Tel. +39 0522 682710 - Fax +39 0522 683552
info@motorpowerco.it - motorpowerco.com
Cap. Soc. 50.960,00 i.v. - R.E.A. di RE 175521
Iscr.Reg.Impr. di RE n.01308390358 - N. Mecc. RE 010210
C.F. e P.IVA IT 01308390358



6.3.6 Velocity Feed Forward

This parameter defines how much of the position reference derivative is fed as a reference to the speed controller.

Parameter	Velocity feed forward
Address	11
Base Address	Axis1=128 , Axis2=320
Access	R/W
Default Values	1000
Range	[0 1000]
Activation	IMMEDIATE

6.3.7 Acceleration Feed Forward

This parameter defines how much of the velocity reference derivative is fed as a reference to the current controller.

Parameter	Acceleration feed forward
Address	12
Base Address	Axis1=128 , Axis2=320
Access	R/W
Default Values	0
Range	[0 1000]
Activation	IMMEDIATE

Motor Power Company s.r.l.

Via Leonardo Da Vinci, 4
42024 Castelnuovo Sotto Reggio Emilia - Italia
Tel. +39 0522 682710 - Fax +39 0522 683552
info@motorpowerco.it - motorpowerco.com
Cap. Soc. 50.960,00 i.v. - R.E.A. di RE 175521
Iscr.Reg.Impr. di RE n.01308390358 - N. Mecc. RE 010210
C.F. e P.IVA IT 01308390358



6.4 Analog Input Functionality

It's possible to use the Analog Input as automatic command generator in Current mode and in Velocity Mode.

6.4.1 Enable Analog Input

Parameter	Enable Analog Input
Address	1
Base Address	Axis1=128 , Axis2=320
Access	R/W
Default Values	0
Range	[0-1]
Activation	IMMEDIATE

Attention!!!! the activation is immediate and if the Servo is on and the Analog input different then zero, the motor will move.

The Gains of the analog input command are calculated as following in the 2 different configuration modes:

Current mode:

$$1V = \frac{(I_{max} * 1000)}{10} A$$

Where I_{max} is the Parameter that define the Peak current of the motor.

Velocity Mode

$$1V = \frac{(Max\ Motor\ Velocity)}{10} [User\ Unit]$$

Where Max Motor Velocity is the parameter that define the Maximum mechanical velocity of the motor.

6.4.2 Analog Safe Zero

It's possible to define a dead-band window for the analog input, in order to allow steady condition when the command is next to 0.

Parameter	Analog Safe Zero
Address	3
Base Address	Axis1=128 , Axis2=320
Access	R/W
Default Values	0 [mV]
Range	[0-10000]
Activation	IMMEDIATE

6.4.3 Analog Offset

If the analog command is not well balanced is possible to define and offset to set the zero value in the correct position.

Parameter	Analog Offset
Address	4
Base Address	Axis1=128 , Axis2=320
Access	R/W
Default Values	0 [mV]
Range	[-10000 10000]
Activation	IMMEDIATE

It's possible to use the Utility present in the Basic PRO User Interface to easily calculate the analog offset coming from the controller.

6.4.4 Analog Filter

If the analog command source is not stable or noisy, it possible to use this parameter to apply a Low Pass filter on the Analog Command Value.

A value of 0 means that the filter is disabled.

Parameter	Analog Filter
Address	5
Base Address	Axis1=128 , Axis2=320
Access	R/W
Default Values	0 [Hz]
Range	[0 10.000]
Activation	IMMEDIATE

6.4.5 Analog Input Fault

On Basic Pro Hardware version 1, is possible to enable an Alarm message when the drive is working in Velocity and Current Mode, and the Analog Cable is disconnected from the drive. A value of 0 means that the control is disabled.

Parameter	Enable Analog Input Fault
Address	94
Base Address	Axis1=128 , Axis2=320
Access	R/W
Default Values	0
Range	[0 1]
Activation	IMMEDIATE

Motor Power Company s.r.l.

Via Leonardo Da Vinci, 4
42024 Castelnuovo Sotto Reggio Emilia - Italia
Tel. +39 0522 682710 - Fax +39 0522 683552
info@motorpowerco.it - motorpowerco.com
Cap. Soc. 50.960,00 i.v. - R.E.A. di RE 175521
Iscr.Reg.Impr. di RE n.01308390358 - N. Mecc. RE 010210
C.F. e P.IVA IT 01308390358



6.4.6 Analog Input Polarity

This parameter allows to reverse the sign of the analog input value (Ex. Change the speed direction). If this parameter is 1 the sign of the analog value will be changed.

Parameter	Analog Input Polarity
Address	2
Base Address	Axis1=128 , Axis2=320
Access	R/W
Default Values	0
Range	[0 1]
Activation	IMMEDIATE

6.5 Brake Parameters

These parameters define the timing of the brake system in the motor when at least one of the digital outputs has been configured with the Brake Functionality.

For safety reasons, a brake-active output releases the brake so that the brake is activated when the drive is not powered on.

For this reason the brake output should always be defined as active low.

When the brake is released at motor start, the drive allows the brake time to disengage before motion begins. During this time, the drive keeps the motor in its starting position. When the motor is turned off, the drive first commands the brake to engage. Then, for a time, it keeps the motor in place while the brake actually engages.

Motor Power Company s.r.l.

Via Leonardo Da Vinci, 4
42024 Castelnuovo Sotto Reggio Emilia - Italia
Tel. +39 0522 682710 - Fax +39 0522 683552
info@motorpowerco.it - motorpowerco.com
Cap. Soc. 50.960,00 i.v. - R.E.A. di RE 175521
Iscr.Reg.Impr. di RE n.01308390358 - N. Mecc. RE 010210
C.F. e P.IVA IT 01308390358



6.5.1 Brake TurnOn Delay

It is the time in ms for Brake disengaging, before starting any movement.

Parameter	Brake TurnOn Delay
Address	70
Base Address	Axis1=128 , Axis2=320
Access	R/W
Default Values	0 [ms]
Range	[0 5000]
Activation	IMMEDIATE

6.5.2 Brake TurnOff Delay

It is the time in ms for the Brake to be engaged before the motor shut down.

Parameter	Brake TurnOff Delay
Address	71
Base Address	Axis1=128 , Axis2=320
Access	R/W
Default Values	0
Range	[0 5000]
Activation	IMMEDIATE

6.6 Safety Parameters

6.6.1 Over Velocity

To avoid not proper operation it's possible to define a safe speed range. The Over Speed parameter define this window.

Parameter	Over velocity
Address	69
Base Address	Axis1=128 , Axis2=320
Access	R/W
Default Values	1000 [rpm]
Range	[0 10000]
Activation	IMMEDIATE

6.7 Homing Parameters

In this chapter are described all the parameters related with the homing functionality embedded into the Basic Pro Firmware.

6.7.1 Homing Method

This parameter describe set the type of homing function will be used in the next execution.

For a complete description of homing functionality refer to the Basic PRO CanOpen Manual.

Parameter	Homing Method
Address	37
Base Address	Axis1=128 , Axis2=320
Access	R/W
Default Values	0
Range	[-128 128]
Activation	IMMEDIATE

List of allowed values

With Index	Without Index	Homing Method Description
-2	-18	Positive Hard Homing
-1	-17	Negative Hard Homing
1	17	Negative Limit Switch
2	18	Positive Limit Switch

Motor Power Company s.r.l.

Via Leonardo Da Vinci, 4
42024 Castelnuovo Sotto Reggio Emilia - Italia
Tel. +39 0522 682710 - Fax +39 0522 683552
info@motorpowerco.it - motorpowerco.com
Cap. Soc. 50.960,00 i.v. - R.E.A. di RE 175521
Iscr.Reg.Impr. di RE n.01308390358 - N. Mecc. RE 010210
C.F. e P.IVA IT 01308390358



3	19	Positive Home Switch (Low)
4	20	Positive Home Switch (High)
5	21	Negative Home Switch (Low)
6	22	Negative Home Switch (High)
7	23	Positive Home Switch (Low) + PLS
8	24	Positive Home Switch (High) + PLS
9	25	Home Switch (Low) + Positive Initial Move
10	26	Home Switch (High) + Positive Initial Move
11	27	Negative Home Switch (Low) + NLS
12	28	Negative Home Switch (High) + NLS
13	29	Home Switch (Low) + Negative Initial Move
14	30	Home Switch (High) + Negative Initial Move
33		Homing to Index + Negative Move
34		Homing to Index + Positive Move
	35	Homing on current position

6.7.2 Home Offset

This parameter define the value that will be stored in the position counter when the homing condition is reached.

Parameter	Home Offset
Address	38,39 (int32)
Base Address	Axis1=128 , Axis2=320
Access	R/W
Default Values	0
Range	[-2147483647 2147483648]
Activation	IMMEDIATE

6.7.3 Homing Speed to Switch

This parameter set the speed that the homing function use to reach the Home switch in rpm.

Parameter	Homing Speed to Switch
Address	40
Base Address	Axis1=128 , Axis2=320
Access	R/W
Default Values	0 [rpm]
Range	[0 10000]
Activation	IMMEDIATE

6.7.4 Homing speed to Index

This parameter set the speed that the homing function use to reach the Index in rpm.

Parameter	Homing Speed to Index
Address	52
Base Address	Axis1=128 , Axis2=320
Access	R/W
Default Values	0 [rpm]
Range	[0 10000]
Activation	IMMEDIATE

6.7.5 Homing Acceleration

This parameter define the homing acceleration and deceleration value in rpm/s.

Parameter	Homing Acceleration
Address	41
Base Address	Axis1=128 , Axis2=320
Access	R/W
Default Values	0 [rpm/s]
Range	[0 65536]
Activation	IMMEDIATE

6.7.6 Post homing action

This parameter define what happen after the homing condition is reached.

Parameter	Post homing action
Address	42
Base Address	Axis1=128 , Axis2=320
Access	R/W
Default Values	0
Range	[0 10]
Activation	IMMEDIATE

List of allowed values

Value	Post homing actions
0	Do Nothing
1	Move to Post Homing Offset

6.7.7 Post homing Offset

This parameter define the position where move the motor if the Post homing action "Move to Post Homing Offset" is activated.

Parameter	Home Offset
Address	47,48 (int32)
Base Address	Axis1=128 , Axis2=320
Access	R/W
Default Values	0
Range	[-2147483647 2147483648]
Activation	IMMEDIATE

6.7.8 Post homing speed

This parameter define the speed in rpm of the post homing action .

Parameter	Post homing Speed
Address	44
Base Address	Axis1=128 , Axis2=320
Access	R/W
Default Values	0 [rpm]
Range	[0 10000]
Activation	IMMEDIATE

For Acceleration and Deceleration of the port homing action is used the Homing Acceleration value.

6.7.9 Homing Timeout

This parameter defines the homing timeout in [s]. If the homing function will not be reached during this time an error will rise.

Parameter	Homing timeout
Address	45
Base Address	Axis1=128 , Axis2=320
Access	R/W
Default Values	0 [s]
Range	[0 65535]
Activation	IMMEDIATE

6.7.10 Homing Current Comparison

This parameter defines which current measuring method is used with homing type -17 and -18.

Parameter	Homing current comparison
Address	49
Base Address	Axis1=128 , Axis2=320
Access	R/W
Default Values	0

Range	[0 1]
Activation	IMMEDIATE

List of allowed values

Value	Description
0	I2T Threshold is used
1	Current Threshold is used

Note: If this value is 1 during homing method different that -17 and -18, a [current limitation](#) will be applied during the homing.

6.7.11 Homing I2t Threshold Value

This parameter define the % of I2t value that rise and homing reached action

Parameter	Homing current comparison
Address	46
Base Address	Axis1=128 , Axis2=320
Access	R/W
Default Values	0 [%]
Range	[1 100]
Activation	IMMEDIATE

6.7.12 Homing Current Threshold Value

This parameter define the % of I_{max} Motor Current value that rise and homing reached action.

Parameter	Homing current threshold value
Address	50
Base Address	Axis1=128 , Axis2=320
Access	R/W
Default Values	0 [%]
Range	[1 100]
Activation	IMMEDIATE

6.7.13 Homing Current Threshold Time

This parameter define the time [ms] where the Homing current threshold value condition have to be active before rising a homing reached action.

Parameter	Homing current threshold value
Address	51
Base Address	Axis1=128 , Axis2=320
Access	R/W
Default Values	0 [ms]
Range	[0 65535]
Activation	IMMEDIATE

6.8 Profile Parameters

In this paragraph describe all the parameters useful for configuring the internal speed and position Interpolator.

6.8.1 Profile Mode

This parameter is used in Velocity mode. If the value is 1 it enable the speed profiler to use acceleration, deceleration and smoothing limits.

Parameter	Homing current threshold value
Address	22
Base Address	Axis1=128 , Axis2=320
Access	R/W
Default Values	1
Range	[0 1]
Activation	IMMEDIATE

6.8.2 Interp Max Vel

This parameter set the maximum velocity [rpm] of the position profile generator.

Parameter	Interp Max Vel
Address	26
Base Address	Axis1=128 , Axis2=320
Access	R/W
Default Values	1000
Range	[0 10000]
Activation	IMMEDIATE

6.8.3 Acceleration

This parameter set the maximum acceleration [rpm/s] used by velocity and position profiler.

Parameter	Acceleration
Address	23
Base Address	Axis1=128 , Axis2=320
Access	R/W
Default Values	1000
Range	[0 65535]
Activation	IMMEDIATE

6.8.4 Deceleration

This parameter set the maximum deceleration [rpm/s] used by velocity and position profiler.

Parameter	Deceleration
Address	24
Base Address	Axis1=128 , Axis2=320

Motor Power Company s.r.l.

Via Leonardo Da Vinci, 4
42024 Castelnuovo Sotto Reggio Emilia - Italia
Tel. +39 0522 682710 - Fax +39 0522 683552
info@motorpowerco.it - motorpowerco.com
Cap. Soc. 50.960,00 i.v. - R.E.A. di RE 175521
Iscr.Reg.Impr. di RE n.01308390358 - N. Mecc. RE 010210
C.F. e P.IVA IT 01308390358



Access	R/W
Default Values	1000
Range	[0 65535]
Activation	IMMEDIATE

6.8.5 Stop Deceleration

This parameter set the deceleration [rpm/s] used by velocity and position profiler under special conditions.

Parameter	Deceleration
Address	25
Base Address	Axis1=128 , Axis2=320
Access	R/W
Default Values	1000
Range	[0 65535]
Activation	IMMEDIATE

6.8.6 Velocity Radius

This parameter configure the target velocity window. If the velocity is between this window the status word bit will reflect this situation.

Parameter	Velocity radius
Address	33
Base Address	Axis1=128 , Axis2=320
Access	R/W
Default Values	100 [rpm]
Range	[0 10000]
Activation	IMMEDIATE

6.8.7 Velocity Radius Time

This parameter configure the time [ms] after that the velocity radius will activate the status word bit.

Parameter	Velocity radius time
Address	34
Base Address	Axis1=128 , Axis2=320
Access	R/W
Default Values	10 [ms]
Range	[0 10000]
Activation	IMMEDIATE

6.8.8 Velocity Threshold

This parameter set the minimum velocity [rpm] value after that the status word will report that the axis is moving.

Parameter	Velocity threshold
Address	35
Base Address	Axis1=128 , Axis2=320
Access	R/W
Default Values	10 [rpm]
Range	[0 10000]
Activation	IMMEDIATE

6.8.9 Velocity Threshold Time

This parameter set the time [ms] value after that the status word will report that the axis is moving.

Parameter	Velocity threshold time
Address	36
Base Address	Axis1=128 , Axis2=320

Access	R/W
Default Values	10 [ms]
Range	[0 10000]
Activation	IMMEDIATE

6.8.10 Velocity Error Radius

This parameter set the velocity error window. If the velocity will leave the window a warning bit will be set in the status word.

Parameter	Velocity error radius
Address	36
Base Address	Axis1=128 , Axis2=320
Access	R/W
Default Values	100 [rpm]
Range	[0 10000]
Activation	IMMEDIATE

6.8.11 Velocity Error Radius Time

This parameter set the time in [ms] after that the velocity radius error will occur

Parameter	Velocity error radius
Address	36
Base Address	Axis1=128 , Axis2=320
Access	R/W
Default Values	100 [rpm]
Range	[0 10000]
Activation	IMMEDIATE

6.8.12 Position Radius

This parameter define the Target Reached window defined in counts.

Parameter	Position radius
Address	30,31 (int32)
Base Address	Axis1=128 , Axis2=320
Access	R/W
Default Values	100 [counts]
Range	[]
Activation	IMMEDIATE

6.8.13 Position Radius Time

This parameter define the time [ms] after that the position reached flag will be set in the status word.

Parameter	Position radius time
Address	33
Base Address	Axis1=128 , Axis2=320
Access	R/W
Default Values	10 [ms]
Range	[0 10000]
Activation	IMMEDIATE

6.8.14 Following Error Window

This parameter define a range of tolerated position values symmetrical to the Position Demand Value. If the Position Actual Value is out of the Following error window for Following Error timeout.

Parameter	Following Error Window
Address	(27,28)
Base Address	Axis1=128 , Axis2=320
Access	R/W
Default Values	500 [Counts]

Range	[0 2 ³¹]
Activation	IMMEDIATE

6.8.15 Following Error Timeout

This parameter set the timeout in [ms] for the Following Error Window

Parameter	Following Error Timeout
Address	29
Base Address	Axis1=128 , Axis2=320
Access	R/W
Default Values	0 [ms]
Range	[0 10000]
Activation	IMMEDIATE

6.8.16 Polarity

This parameter allow to change the polarity of position and speed.

Parameter	Polarity
Address	103
Base Address	Axis1=128 , Axis2=320
Access	R/W
Default Values	0
Range	[0 255]
Activation	IMMEDIATE

The following table show the list of possible values:

bit	Description
0	reserved
1	reserved
2	reserved

Motor Power Company s.r.l.

Via Leonardo Da Vinci, 4
42024 Castelnovo Sotto Reggio Emilia - Italia
Tel. +39 0522 682710 - Fax +39 0522 683552
info@motorpowerco.it - motorpowerco.com
Cap. Soc. 50.960,00 i.v. - R.E.A. di RE 175521
Iscr.Reg.Impr. di RE n.01308390358 - N. Mecc. RE 010210
C.F. e P.IVA IT 01308390358



3	reserved
4	reserved
5	reserved
6	Velocity Polarity
7	Position Polarity

Motor Power Company s.r.l.

Via Leonardo Da Vinci, 4
42024 Castelnuovo Sotto Reggio Emilia - Italia
Tel. +39 0522 682710 - Fax +39 0522 683552
info@motorpowerco.it - motorpowerco.com
Cap. Soc. 50.960,00 i.v. - R.E.A. di RE 175521
Iscr.Reg.Impr. di RE n.01308390358 - N. Mecc. RE 010210
C.F. e P.IVA IT 01308390358



6.8.17 Software Position Limits

Positive Software Limit

Parameter	Positive software Limit
Address	80,81
Base Address	Axis1=128 , Axis2=320
Access	R/W
Default Values	----- MAX
Range	[-]
Activation	IMMEDIATE

Negative Software Limit

Parameter	Negative software Limit
Address	78,79
Base Address	Axis1=128 , Axis2=320
Access	R/W
Default Values	----- MAX
Range	[-]
Activation	IMMEDIATE

Motor Power Company s.r.l.

Via Leonardo Da Vinci, 4
42024 Castelnuovo Sotto Reggio Emilia - Italia
Tel. +39 0522 682710 - Fax +39 0522 683552
info@motorpowerco.it - motorpowerco.com
Cap. Soc. 50.960,00 i.v. - R.E.A. di RE 175521
Iscr.Reg.Impr. di RE n.01308390358 - N. Mecc. RE 010210
C.F. e P.IVA IT 01308390358



6.9 Control Loop Tuning Parameters

These parameters are useful for tuning the current loop. The wave that is generated automatically from the system has the amplitude of the nominal current of the motor. The delay is useful to put the waveform in the best position, the frequency = 1/Period and the Duty Cycle give us the ability to create the best waveform for the motor.

	This functionality must be used only by advanced users
---	--

These parameter works only if the system is operating in control mode -4.

To activate the wave a begin command must be issued.

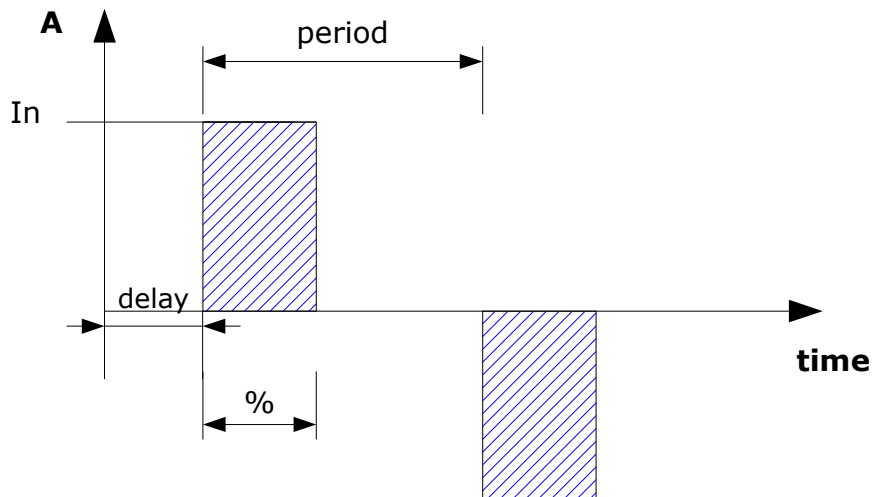

Image 1: Current Loop Tuning

6.9.1 Current Tuning Freq

Parameter	Current Tuning Frequency
Address	71

Base Address	Axis1=128 , Axis2=320
Access	R/W
Default Values	20 [Hz]
Range	[1,65534]
Activation	IMMEDIATE

6.9.2 Current Tuning Delay

Parameter	Current Tuning Delay
Address	81
Base Address	Axis1=128 , Axis2=320
Access	R/W
Default Values	0
Range	[0 100]
Activation	IMMEDIATE

6.9.3 Current Tuning DutyCycle

Parameter	Current setpoint polarity
Address	82
Base Address	Axis1=128 , Axis2=320
Access	R/W
Default Values	50 [%]
Range	[0,100]
Activation	IMMEDIATE

6.10 Static PDO Mapping Parameters

With Basic PRO it's possible to save a static mapping of TPDO and RPDO 1 and 2. Even if this mapping is saved into E2Prom of the drive it's always possible to change that mapping with the CanOpen DS 301 protocol.

6.11 Status Word Masking

For compatibility reasons it's possible to use this mask to hide the Manufacturer specific bit of the Status word. The mask affect all status word, please change only the 2 most significative bits if needed.

Parameter	Status Word Masking
Address	123
Base Address	Axis1=128 , Axis2=320
Access	R/W
Default Values	65535
Range	[0, 65535]
Activation	REBOOT

6.12 Boot NMT Status

With this parameter is possible to select the Boot NMT status.

Parameter	Status Word Masking
Address	124
Base Address	Axis1=128 , Axis2=320
Access	R/W
Default Values	0
Range	[0, 0x04]
Activation	REBOOT

List of possible values:

Value	Description
0x00	Pre-Operational
0x04	Operational

6.13 Static PDO Mapping

The following parameters allow the user to define a static PDO mapping for RPDO and TPDO 1,2.

For a detailed description of these parameter refer to BASIC PRO CanOpen Manual.

Parameter	Static PDO Mapping
Address	136-186
Base Address	Axis1=128 , Axis2=320
Access	R/W
Default Values	-
Range	[0x0, 0xFFFFFFFF]
Activation	REBOOT

Address	Description	
136	CanOpen @ 1400,01	COB ID RPDO1
138	CanOpen @ 1400,02	Transmission Type
142	CanOpen @ 1600,00	Number Of Entries
143	CanOpen @ 1600,01	RPDO1 Mapping 0
145	CanOpen @ 1600,02	RPDO1 Mapping 1
147	CanOpen @ 1600,03	RPDO1 Mapping 2
149	CanOpen @ 1600,04	RPDO1 Mapping 3
160	CanOpen @ 1800,01	COB ID TPDO1
162	CanOpen @ 1800,02	Transmission Type
163	CanOpen @ 1800,03	Inhibit Time
164	CanOpen @ 1800,05	Event Timer
170	CanOpen @ 1A00,0	Number Of Entries
171	CanOpen @ 1A00,01	TPDO1 Mapping 0
173	CanOpen @ 1A00,02	TPDO1 Mapping 1
175	CanOpen @ 1A00,03	TPDO1 Mapping 2
177	CanOpen @ 1A00,04	TPDO1 Mapping 3
139	CanOpen @ 1401,01	COB ID RPDO2
141	CanOpen @ 1401,02	Transmission Type

Motor Power Company s.r.l.

Via Leonardo Da Vinci, 4
42024 Castelnuovo Sotto Reggio Emilia - Italia
Tel. +39 0522 682710 - Fax +39 0522 683552
info@motorpowerco.it - motorpowerco.com
Cap. Soc. 50.960,00 i.v. - R.E.A. di RE 175521
Iscr.Reg.Impr. di RE n.01308390358 - N. Mecc. RE 010210
C.F. e P.IVA IT 01308390358



151	CanOpen @ 1601,00	Number Of Entries
152	CanOpen @ 1601,01	RPDO2 Mapping 0
154	CanOpen @ 1601,02	RPDO2 Mapping 1
156	CanOpen @ 1601,03	RPDO2 Mapping 2
158	CanOpen @ 1601,04	RPDO2 Mapping 3
165	CanOpen @ 1801,01	COB ID TPDO2
167	CanOpen @ 1801,02	Transmission Type
168	CanOpen @ 1801,03	Inhibit Time
169	CanOpen @ 1801,05	Event Timer
179	CanOpen @ 1A01,0	Number Of Entries
180	CanOpen @ 1A01,01	TPDO2 Mapping 0
182	CanOpen @ 1A01,02	TPDO2 Mapping 1
184	CanOpen @ 1A01,03	TPDO2 Mapping 2
186	CanOpen @ 1A01,04	TPDO2 Mapping 3

Note: To disable a Static PDO mapping the Msb (Most significant bit) must be set.

Example:

Parameter 136:

0x80000181 PDO DISABLED
0x00000181 PDO ENABLED

6.14 Torque Limits

6.14.1 Positive Torque Limit

Parameter	Positive Torque Limit
Address	126
Base Address	Axis1=128 , Axis2=320
Access	R/W
Default Values	100

Range	[0 100]%
Activation	Immediate

6.14.2 Negative Torque Limit

Parameter	Negative Torque Limit
Address	127
Base Address	Axis1=128 , Axis2=320
Access	R/W
Default Values	100
Range	[0 100]%
Activation	Immediate

6.15 JOG Parameters

6.15.1 JOG Positive

Parameter	JOG Positive Axis
Address	[116,117]
Base Address	Axis1=128 , Axis2=320
Access	R/W
Default Values	100
Range	(32 bit) [0 100]%
Activation	Immediate

Motor Power Company s.r.l.

Via Leonardo Da Vinci, 4
42024 Castelnuovo Sotto Reggio Emilia - Italia
Tel. +39 0522 682710 - Fax +39 0522 683552
info@motorpowerco.it - motorpowerco.com
Cap. Soc. 50.960,00 i.v. - R.E.A. di RE 175521
Iscr.Reg.Impr. di RE n.01308390358 - N. Mecc. RE 010210
C.F. e P.IVA IT 01308390358



6.15.2 JOG Negative Axis

Parameter	JOG Negative
Address	[118,119]
Base Address	Axis1=128 , Axis2=320
Access	R/W
Default Values	100
Range	(32 bit) [0 100]%
Activation	Immediate

Motor Power Company s.r.l.

Via Leonardo Da Vinci, 4
42024 Castelnuovo Sotto Reggio Emilia - Italia
Tel. +39 0522 682710 - Fax +39 0522 683552
info@motorpowerco.it - motorpowerco.com
Cap. Soc. 50.960,00 i.v. - R.E.A. di RE 175521
Iscr.Reg.Impr. di RE n.01308390358 - N. Mecc. RE 010210
C.F. e P.IVA IT 01308390358



Chapter 7: Generic Inputs

With the generic inputs is possible to send general command useful for the drive. All the commands will be activated only on the rising edge transition.

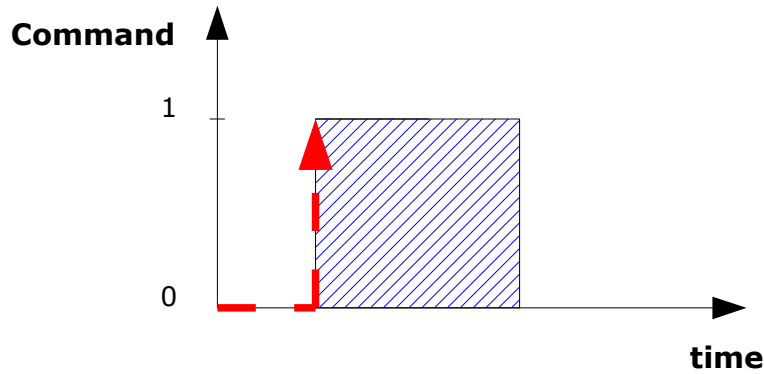

Image 2: Rising edge

7.1 Save To Flash

With this command is possible to save the actual configuration present in the RAM into the E2PROM (non volatile memory) so it will be available at next boot.

This command will save all the Parameters (Generic, Axis1 and Axis2)



The communication with the drive will be lost for some second when this command is executed.
During the execution of this command both the servo must be switched off.

Input	Save to flash
Address	2
Base Address	512
Access	R/W

Default Values	0
Range	[0,1]
Activation	IMMEDIATE

7.2 Set Default Parameters

This command will copy the default parameter configuration into the RAM. A save to Flash have to be done after this operation.

Input	Set default parameters
Address	3
Base Address	512
Access	R/W
Default Values	0
Range	[0,1]
Activation	IMMEDIATE



It important to reboot the device after this operation.

7.3 Reset Drive

This command will perform a software Reset of the Drive. If an upper board is present please always remove the 24 V Backup Voltage to perform a safe Drive Reset.

Input	Reset Drive
Address	4
Base Address	512
Access	R/W

Motor Power Company s.r.l.

Via Leonardo Da Vinci, 4
42024 Castelnuovo Sotto Reggio Emilia - Italia
Tel. +39 0522 682710 - Fax +39 0522 683552
info@motorpowerco.it - motorpowerco.com
Cap. Soc. 50.960,00 i.v. - R.E.A. di RE 175521
Iscr.Reg.Impr. di RE n.01308390358 - N. Mecc. RE 010210
C.F. e P.IVA IT 01308390358



Default Values	0
Range	[0,1]
Activation	IMMEDIATE



It important to Reset the Drive only if the Servo are disabled.

7.4 Start Bootloader

This parameter will force the drive to switch to Bootloader mode, and allow a new firmware to be loaded on the device.

Input	Start Bootloader
Address	5
Base Address	512
Access	R/W
Default Values	0
Range	[0,1]
Activation	IMMEDIATE

7.5 Force Output

This input force the state of the output if they are configured as a General Purpose Output. Bit 0 of the word correspond to Output_1 on the drive.

Input	Force Output
Address	23
Base Address	512
Access	R/W
Default Values	0

Motor Power Company s.r.l.

Via Leonardo Da Vinci, 4
42024 Castelnuovo Sotto Reggio Emilia - Italia
Tel. +39 0522 682710 - Fax +39 0522 683552
info@motorpowerco.it - motorpowerco.com
Cap. Soc. 50.960,00 i.v. - R.E.A. di RE 175521
Iscr.Reg.Impr. di RE n.01308390358 - N. Mecc. RE 010210
C.F. e P.IVA IT 01308390358



Range	[0 - 65535]
Activation	IMMEDIATE

7.6 Password

Reserved, Only for advanced users.

Input	Password
Address	27
Base Address	512
Access	R/W
Default Values	0
Range	[0 - 65535]
Activation	IMMEDIATE

Motor Power Company s.r.l.

Via Leonardo Da Vinci, 4
42024 Castelnuovo Sotto Reggio Emilia - Italia
Tel. +39 0522 682710 - Fax +39 0522 683552
info@motorpowerco.it - motorpowerco.com
Cap. Soc. 50.960,00 i.v. - R.E.A. di RE 175521
Iscr.Reg.Impr. di RE n.01308390358 - N. Mecc. RE 010210
C.F. e P.IVA IT 01308390358



Chapter 8: Axis Inputs

With Axis input is possible to send command to each axis of the device and set the set point for all the mode of operation.

8.1 Control Word

The internal state machine of each single axis is commanded from one single command that is the Control Word. The Basic PRO control word act as a CanOpen Control Word, for more information on it's bits please refer to the Basic PRO CanOpen Manual.

Input	Set default parameters
Address	0
Base Address	Axis1=540, Axis2=590
Access	R/W
Default Values	0
Range	[0,65535]
Activation	RISING-EDGE

For faster and easier use of the system, we took some important bit of the control word and we put into different inputs. Changing these inputs will immediately change the status of the Control Word.

8.1.1 Enable

This input allow the user to turn of the servo.

Input	Enable
Address	6
Base Address	Axis1=540, Axis2=590
Access	R/W
Default Values	0

Motor Power Company s.r.l.

Via Leonardo Da Vinci, 4
42024 Castelnuovo Sotto Reggio Emilia - Italia
Tel. +39 0522 682710 - Fax +39 0522 683552
info@motorpowerco.it - motorpowerco.com
Cap. Soc. 50.960,00 i.v. - R.E.A. di RE 175521
Iscr.Reg.Impr. di RE n.01308390358 - N. Mecc. RE 010210
C.F. e P.IVA IT 01308390358



Range	[0,1]
Activation	RISING-EDGE

Note: All the parameter and the Control Filter must be correctly set before the motor can move correctly.

8.1.2 Begin

This input allow the user to commit one set point depending on the actual mode of operation.

Input	Begin
Address	7
Base Address	Axis1=540, Axis2=590
Access	R/W
Default Values	0
Range	[0,1]
Activation	RISING-EDGE

8.1.3 Fault Reset

This input allow to reset all the fault present on the system. If all the error are reset the changes will be visible both on the error register and the Status Word.

Input	Fault Reset
Address	8
Base Address	Axis1=540, Axis2=590
Access	R/W
Default Values	0
Range	[0,1]
Activation	RISING-EDGE

8.1.4 Halt

This input allow the user to stop the actual movement both in Position and Velocity mode. The axis will be stopped (0 Velocity) with the Stop Deceleration.

Input	Halt
Address	9
Base Address	Axis1=540, Axis2=590
Access	R/W
Default Values	0
Range	[0,1]
Activation	RISING-EDGE

8.1.5 Set immediately

This input reflect exactly the Control Word bit and allow the user to define if the following command activated with the Begin bit will be executed immediately or it will wait the execution of a previous command.

If this bit is set to 1 all the commands will be executed immediately.

Input	Set immediately
Address	10
Base Address	Axis1=540, Axis2=590
Access	R/W
Default Values	0
Range	[0,1]
Activation	IMMEDIATE

8.1.6 Use Relative Position

This input is necessary to define if the Position set point of the next position command is absolute or relative.

If this bit is set to 1 the next position command will be relative.

Input	Use relative position
Address	11
Base Address	Axis1=540, Axis2=590
Access	R/W
Default Values	0
Range	[0,1]
Activation	IMMEDIATE

8.2 Targets

8.2.1 Current Target

This input define the Current Target in [mA] of the Current Loop. The new set point will be activated with the Begin command.

Input	Current target
Address	12
Base Address	Axis1=540, Axis2=590
Access	R/W
Default Values	0
Range	[0 - 15000]
Activation	IMMEDIATE

8.2.2 Speed Target

This input define the speed target in [rpm]. The new set point will be activated with the Begin command. The speed target will be affected by Profile mode parameter.

Input	Current target
Address	13
Base Address	Axis1=540, Axis2=590

Motor Power Company s.r.l.

Via Leonardo Da Vinci, 4
42024 Castelnuovo Sotto Reggio Emilia - Italia
Tel. +39 0522 682710 - Fax +39 0522 683552
info@motorpowerco.it - motorpowerco.com
Cap. Soc. 50.960,00 i.v. - R.E.A. di RE 175521
Iscr.Reg.Impr. di RE n.01308390358 - N. Mecc. RE 010210
C.F. e P.IVA IT 01308390358



Access	R/W
Default Values	0 [rpm]
Range	[0 - 10000]
Activation	IMMEDIATE

8.2.3 Position Target

This input define the position target in [counts]. The new set point will be activated with the Begin command. The speed target will be affected by "[Use relative position](#)" bit of the Control Word.

Input	Position target
Address	14,15 (int32)
Base Address	Axis1=540, Axis2=590
Access	R/W
Default Values	0 [count]
Range	[-1073741824 - 1073741824]
Activation	IMMEDIATE

Chapter 9: Generic Outputs

These variable show the status of the servo drive, and the most important variables. These values are read only and are updated real time by the Basic PRO.

9.1 Firmware Version

This output value contain the firmware version of the device.

Output	Firmware version
--------	------------------

Address	0
Base Address	640
Access	R
Unit	[-]
Range	[0 - 65535]
Type	String

How to read Firmware Version: Take the 5 digit number of this Output and split as follows:

aa.bb.c

Value	Description
aa	Version
bb	Revision
c	Minor

9.2 Flash Status

This output show if the status bits of the internal flash.

Output	Flash Status
Address	27
Base Address	640
Access	R
Unit	[-]
Range	[0 65535]
Type	UNSIGNED

List of possible Values:

bit	Description
0-10	Current parameter being saved
11	Reserved

12	Reserved
13	Default parameters Loaded
14	Parameters Stored Correctly
15	Parameters Loaded Correctly

9.3 DC Bus Voltage

This Value show the DC Bus Voltage expressed in [V].

Output	DC Bus
Address	13
Base Address	640
Access	R
Unit	[V]
Range	[0 - 800]
Type	Int

9.4 DC Bus Offset

This value show the DC Bus offset correction.

Output	DC Bus
Address	9
Base Address	640
Access	R
Unit	[V]
Range	[0 - 800]
Type	Int

9.5 Input bits

This output show the status of the real input bit. Each bit of this word rapresent the status of each input pin.

Output	Input bits
Address	23
Base Address	640
Access	R
Unit	
Range	[0 - 65535]
Type	bit

9.6 Output bits

This value show the status of the Digital Outputs.

Output	Digital Input
Address	24
Base Address	640
Access	R
Unit	
Range	[0 - 65535]
Type	bit

9.7 Can Bus Outputs

The following output values show the status of the Can Variables and the Can Register of the DSP.

9.7.1 Vendor ID

The vendor ID is a specific code given by Cia (Can in Automation <http://www.cancia.org/>). Actually Basic PRO is not a Registered device and is Vendor ID is set to 1. This value is provided for CanOpen compatibility reasons.

Output	Vendor ID
Address	1,2
Base Address	640
Access	R
Unit	-
Range	[0 - 2 ³²]
Type	Long (32 bit)

9.7.2 Product Code

The Product Code is a specific identification given by Motor Power Company for this Device. This value is provided for CanOpen compatibility reasons.

Output	Product Code
Address	3,4
Base Address	640
Access	R
Unit	-
Range	[0 - 2 ³²]
Type	Long (32 bit)

9.7.3 Revision Number

The Revision Number is a specific code given by Motor Power Company for this Device. This value is provided for CanOpen compatibility reasons.

Output	Revision Number
Address	5,6
Base Address	640
Access	R
Unit	-
Range	[0 - 2 ³²]
Type	Long (32 bit)

9.7.4 Serial Number

The Serial Number is a unique code given by Motor Power Company for this Device. This value is provided for CanOpen compatibility reasons.

Output	Serial Number
Address	7,8
Base Address	640
Access	R
Unit	-
Range	[0 - 2 ³²]
Type	Long (32 bit)

9.7.5 Can Tx Error Counter

This value is a counter of the failed transmission on the Can Network.

Output	Can Tx Error Counter
Address	11
Base Address	640
Access	R
Unit	-
Range	[0 - 2 ³²]
Type	Int (16 bit)

9.7.6 Can Rx Error Counter

This value is a counter of the bad frame received on the Can Network.

Output	Can Rx Error Counter
Address	12
Base Address	640

Access	R
Unit	-
Range	[0 - 2 ³²]
Type	Int (16 bit)

9.7.7 CAN Status Register

Specific CAN Status register.

Output	Can Status Register
Address	18
Base Address	640
Access	R
Unit	-
Range	[0 - 2 ³²]
Type	Int (16 bit)

9.7.8 CAN Error Register

Specific CAN Status register.

Output	Can Error Register
Address	19
Base Address	640
Access	R
Unit	-
Range	[0 - 2 ³²]
Type	uint (16 bit)

Chapter 10: Axis Outputs

Motor Power Company s.r.l.

Via Leonardo Da Vinci, 4
42024 Castelnuovo Sotto Reggio Emilia - Italia
Tel. +39 0522 682710 - Fax +39 0522 683552
info@motorpowerco.it - motorpowerco.com
Cap. Soc. 50.960,00 i.v. - R.E.A. di RE 175521
Iscr.Reg.Impr. di RE n.01308390358 - N. Mecc. RE 010210
C.F. e P.IVA IT 01308390358



10.1 Status Word

This output report the status of the internal state machine of Basic PRO. Refer to CanOpen Manual for more information.

Output	Status word
Address	0
Base Address	Axis1=668 , Axis2=718
Access	R
Unit	-
Range	[0 - 65535]
Type	uint (16 bit)

10.2 Fault Register

This output report if the Axis has one fault or is correctly running. Each bit of the Fault register rapresent a fault condition. It's possible to have one ore more fault condition activated.

Output	Fault Register
Address	1
Base Address	Axis1=668 , Axis2=718
Access	R
Unit	-
Range	[0 - 65535]
Type	UINT (16 bit)

The following error are allowed on the Basic PRO system:

bit	Error
0	Over Voltage
1	Under Voltage
2	Peak Motor Current
3	Rated Motor Current
4	Short Circuit

Motor Power Company s.r.l.

Via Leonardo Da Vinci, 4
42024 Castelnuovo Sotto Reggio Emilia - Italia
Tel. +39 0522 682710 - Fax +39 0522 683552
info@motorpowerco.it - motorpowerco.com
Cap. Soc. 50.960,00 i.v. - R.E.A. di RE 175521
Iscr.Reg.Impr. di RE n.01308390358 - N. Mecc. RE 010210
C.F. e P.IVA IT 01308390358



5	Rated Brake Current
6	Hall Signals
7	Analog Input
8	Position Tracking
9	Velocity Tracking
10	Over-velocity
11	reserved
12	reserved
13	reserved
14	reserved
15	reserved

10.3 Control Mode Display

This output show the actual mode of operation configured.

Output	Control mode display
Address	2
Base Address	Axis1=668 , Axis2=718
Access	R
Unit	-
Range	[0 - 65535]
Type	uint (16 bit)

For a list of possible value check [Modes of Operation](#) parameter.

10.4 Analog Input

This output show the value that the ADC read from the Axis Analog Input in [mV].

Output	Analog Input
Address	3

Base Address	Axis1=668 , Axis2=718
Access	R
Unit	[mv]
Range	[0 - 65535]
Type	uint (16 bit)

10.5 Hall Signals Value

This value show the value read from the Hall signals. This value is useful to check if the feedback is well connected, and correctly phased.

Output	Hall signals
Address	4
Base Address	Axis1=668 , Axis2=718
Access	R
Unit	[-]
Range	[0 - 7]
Type	uint (16 bit)

If the hall signal value are not correct values (0 or 7) this will generate an hall signal Fault.

10.6 Current Output

The following outputs are all the important value for the current controller.

10.6.1 Iq Target

This value is the IQ Current set point in [mArms].

Output	Iq target
Address	20
Base Address	Axis1=668 , Axis2=718
Access	R

Unit	[mA]
Range	[-32767 32768]
Type	int (16 bit)

10.6.2 Actual Iq

This value is the IQ Current value [mArms].

Output	Actual Iq
Address	6
Base Address	Axis1=668 , Axis2=718
Access	R
Unit	[mA]
Range	[-32767 32768]
Type	int (16 bit)

10.6.3 Iq Error

This value is the difference between IqTarget and Actual Iq value [mArms]. This value will feed the Current Profiler to generate a IqDemand.

Output	Iq error
Address	21
Base Address	Axis1=668 , Axis2=718
Access	R
Unit	[mA]
Range	[-32767 32768]
Type	int (16 bit)

Actually the Current Interpolator is not active so IqTarget will feed immediately the Iq Demand.

10.6.4 Iq Demand

This value is the Actual Iq Demand. This is the real actual current demand.

Output	Iq demand
Address	5
Base Address	Axis1=668 , Axis2=718
Access	R
Unit	[mA]
Range	[-32767 32768]
Type	int (16 bit)

10.6.5 Iq Tracking Error

This value is the difference between IqDemand and Actual Iq value [mArms], hence the real error that is present on the current controller.

Output	Iq tracking error
Address	22
Base Address	Axis1=668 , Axis2=718
Access	R
Unit	[mA]
Range	[-32767 32768]
Type	int (16 bit)

10.7 Velocity Outputs

The following outputs represent all the important value for the speed controller.

10.7.1 Velocity Target

This value is the Speed set-point that feed the speed profiler [rpm].

Output	Velocity target
--------	-----------------

Address	23
Base Address	Axis1=668 , Axis2=718
Access	R
Unit	[rpm]
Range	[-32767 32768]
Type	int (16 bit)

10.7.2 Actual Velocity

This value represent the actual speed of the motor [rpm].

Output	Actual velocity
Address	8
Base Address	Axis1=668 , Axis2=718
Access	R
Unit	[rpm]
Range	[-32767 32768]
Type	int (16 bit)

10.7.3 Velocity Error

This value represent the difference between Velocity Target and Actual velocity [rpm].

Output	Velocity error
Address	24
Base Address	Axis1=668 , Axis2=718
Access	R
Unit	[rpm]
Range	[-32767 32768]
Type	int (16 bit)

10.7.4 Velocity Demand

This value represent the actual velocity demand coming from the speed profiler.

Output	Velocity demand
Address	7
Base Address	Axis1=668 , Axis2=718
Access	R
Unit	[rpm]
Range	[-32767 32768]
Type	int (16 bit)

10.7.5 Velocity Tracking Error

This value rapresent the difference between Velocity Demand and Actual Velocity value [rpm], ence the real error that is present on the speed controller.

Output	Velocity tracking error
Address	25
Base Address	Axis1=668 , Axis2=718
Access	R
Unit	[rpm]
Range	[-32767 32768]
Type	int (16 bit)

10.8 Position Outputs

The following outputs rapresent all the important value for the position controller.

10.8.1 Position Target

This value is the position set-point [Counts].

Output	Position target
Address	26,27
Base Address	Axis1=668 , Axis2=718
Access	R
Unit	[counts]
Range	[]
Type	long (32 bit)

10.8.2 Actual Position

This value is the position actual of the motor [Counts]

Output	Actual position
Address	11,12
Base Address	Axis1=668 , Axis2=718
Access	R
Unit	[counts]
Range	[]
Type	long (32 bit)

10.8.3 Position Error

This value is the difference between Position Target and Actual Position [Counts]. This error will feed the Position Profiler.

Output	Position error
Address	13,14
Base Address	Axis1=668 , Axis2=718
Access	R
Unit	[counts]
Range	[]
Type	long (32 bit)

10.8.4 Position Demand

This value is the output of the Position Profiler, hence the Actual Position Demand [Counts]

Output	Position demand
Address	9,1
Base Address	Axis1=668 , Axis2=718
Access	R
Unit	[counts]
Range	[]
Type	long (32 bit)

10.8.5 Position Tracking Error

This value is the difference between Position Demand and Actual Position [Counts]. This error of the Position Loop.

Output	Position tracking error
Address	28,29
Base Address	Axis1=668 , Axis2=718
Access	R
Unit	[counts]
Range	[]
Type	long (32 bit)

10.8.6 In Position

This value is a flag that report that the position of the the motor is within the limit, so the movement is completed.

Output	In position
Address	15
Base Address	Axis1=668 , Axis2=718
Access	R
Unit	[-]
Range	[0 1]
Type	bool (1 bit)

10.8.7 Interp Ready

This value is a flag that report that the position profiler has finished his job.

Output	Interp ready
Address	16
Base Address	Axis1=668 , Axis2=718
Access	R
Unit	[-]
Range	[0 1]
Type	bool (1 bit)

10.9 Homing Status

Output	Homing Status
Address	34
Base Address	Axis1=668 , Axis2=718
Access	R
Unit	[-]
Range	[0 10]
Type	Unsigned Int

This parameter show the status of the homing process. The status can have the following values:

bit	Error
-----	-------

0	Idle
1	Moving to Switch
2	Moving from Switch
3	Moving From Limit Switch
4	Moving to Zero
5	Halted
6	Timeout
7	Error
8	Attained – Axis Still Moving
9	Post Homing Action
10	Completed

10.10 Motor Usage

This value show the percentage use of the motor. If the value reach 100%, the motor will be stopped with I2T error.

Output	Motor Usage
Address	19
Base Address	Axis1=668 , Axis2=718
Access	R
Unit	[%]
Range	[0 100]
Type	Int (16 bit)

10.11 Axis Enabled

This value is 1 when the servo is enabled. This parameter can be used in connection with [Enable](#) (Input) to create a safe protocol.

Output	Axis Enabled
Address	18
Base Address	Axis1=668 , Axis2=718
Access	R

Unit	[bit]
Range	[0 1]
Type	Bool

10.12 Axis Status

This value show the status of some internal useful bits

Output	Axis Status
Address	49
Base Address	Axis1=668 , Axis2=718
Access	R
Unit	[bit]
Range	[0 65535]
Type	UNSIGNED

List of possible values:

bit	Description
0	Voltage Enabled.
1	First commutation found.

10.13 NMT State

This value show the actual status of the CanOpen network on the axis.

Output	NMT state
Address	31
Base Address	Axis1=668 , Axis2=718
Access	R
Unit	[-]
Range	[0 20]
Type	Int (16 bit)

Motor Power Company s.r.l.

Via Leonardo Da Vinci, 4
42024 Castelnuovo Sotto Reggio Emilia - Italia
Tel. +39 0522 682710 - Fax +39 0522 683552
info@motorpowerco.it - motorpowerco.com
Cap. Soc. 50.960,00 i.v. - R.E.A. di RE 175521
Iscr.Reg.Impr. di RE n.01308390358 - N. Mecc. RE 010210
C.F. e P.IVA IT 01308390358



Motor Power Company s.r.l.

Via Leonardo Da Vinci, 4
42024 Castelnuovo Sotto Reggio Emilia - Italia
Tel. +39 0522 682710 - Fax +39 0522 683552
info@motorpowerco.it - motorpowerco.com
Cap. Soc. 50.960,00 i.v. - R.E.A. di RE 175521
Iscr.Reg.Impr. di RE n.01308390358 - N. Mecc. RE 010210
C.F. e P.IVA IT 01308390358



10.14 Latch Position Output

10.14.1 Positive Edge Position Latch

Output	Positive Edge Position Latch
Address	40,41
Base Address	Axis1=668 , Axis2=718
Access	R
Unit	[Integer]
Range	[]
Type	Long (32 bit)

10.14.2 Negative Edge Position Latch

Output	Negative Edge Position Latch
Address	41,42
Base Address	Axis1=668 , Axis2=718
Access	R
Unit	[Integer]
Range	[]
Type	Long (32 bit)

Motor Power Company s.r.l.

Via Leonardo Da Vinci, 4
42024 Castelnovo Sotto Reggio Emilia - Italia
Tel. +39 0522 682710 - Fax +39 0522 683552
info@motorpowerco.it - motorpowerco.com
Cap. Soc. 50.960,00 i.v. - R.E.A. di RE 175521
Iscr.Reg.Impr. di RE n.01308390358 - N. Mecc. RE 010210
C.F. e P.IVA IT 01308390358



Chapter 11: The Controller

This chapter, which provides details about the speed and position control algorithms, is written for the advanced user who wants to tune the have more information on Basic PRO.

Familiarity with basic digital control theory is mandatory.

The type of controller used depends on the Basic PRO [Mode of Operation](#).

11.1 Current Controller

This paragraph describes the current controller of Basic PRO. Also included are a description of the current limiting process and the drive protections.

Basic PRO energize all three motor terminals simultaneously. This means that it must control two current components simultaneously, because the phase currents are linearly dependent (the sum of all phase currents is zero). The Basic PR drive's vector current controller directly controls the following two current components:

- ✓ **I_Q** : current component that produces a magnetic field in the desired direction (normally perpendicular to the rotor fixed magnet field)
- ✓ **I_D** : current component that produces a magnetic field orthogonal to the desired direction (normally parallel to the rotor fixed magnet field)

The following diagram describes the structure of the current controller:

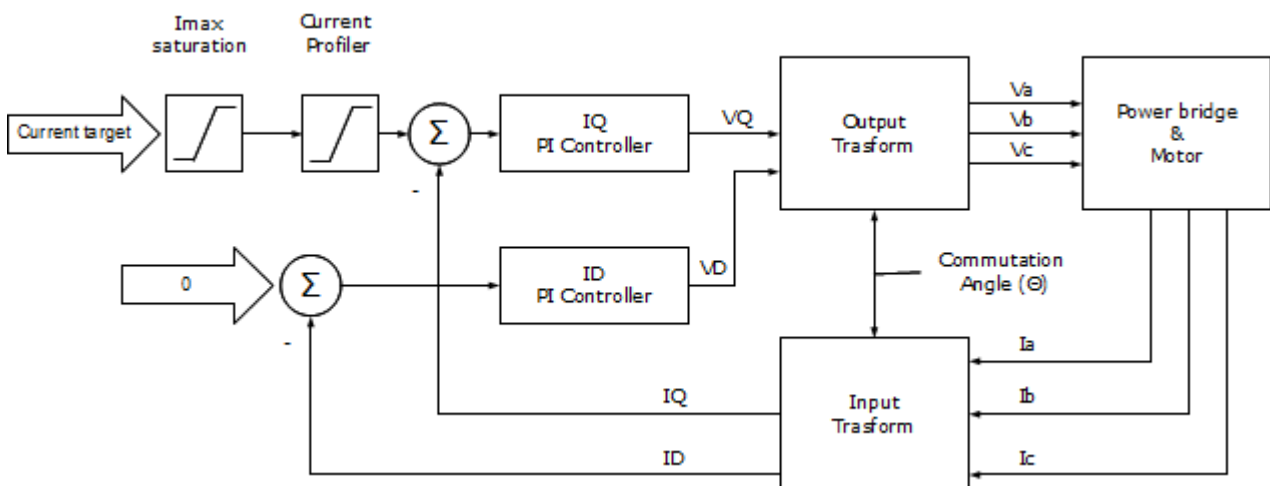

Image 3: Current controller diagram

The input coordinate transform retrieves the IQ and ID (active and reactive) components of the motor current.

$$I_Q = I_a h(\Theta) + I_b h(\Theta + 120^\circ) + I_c h(\Theta + 240^\circ)$$

and

$$I_D = I_a h(\Theta + 90^\circ) + I_b h(\Theta + 210^\circ) + I_c h(\Theta + 330^\circ)$$

where:

Θ is the commutation angle.

$h(\Theta)$ is the input winding function.

The output coordinate transform predicts the variation of the phase voltages during the motor rotation:

$$V_A = V_Q g(\Theta) + V_D g(\Theta + 90^\circ)$$

$$V_B = V_Q g(\Theta + 120^\circ) + V_D g(\Theta + 210^\circ)$$

$$V_C = V_Q g(\Theta + 240^\circ) + V_D g(\Theta + 330^\circ)$$

where:

$g(\Theta)$ is the output winding function.

For sinusoidal motors, $h(\Theta) \equiv \cos(\Theta)$ and $g(\Theta) \equiv \cos(\Theta)$.

11.2 Speed Controller

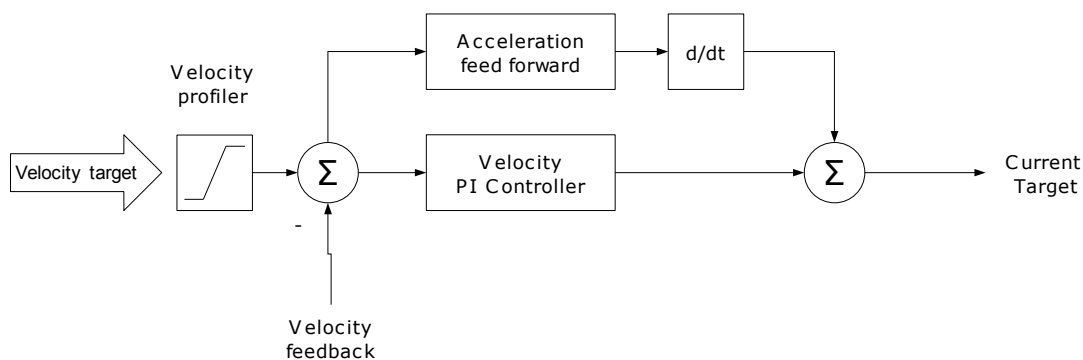

Image 4: Speed controller diagram

Motor Power Company s.r.l.

Via Leonardo Da Vinci, 4
42024 Castelnuovo Sotto Reggio Emilia - Italia
Tel. +39 0522 682710 - Fax +39 0522 683552
info@motorpowerco.it - motorpowerco.com
Cap. Soc. 50.960,00 i.v. - R.E.A. di RE 175521
Iscr.Reg.Impr. di RE n.01308390358 - N. Mecc. RE 010210
C.F. e P.IVA IT 01308390358



11.3 Position Controller

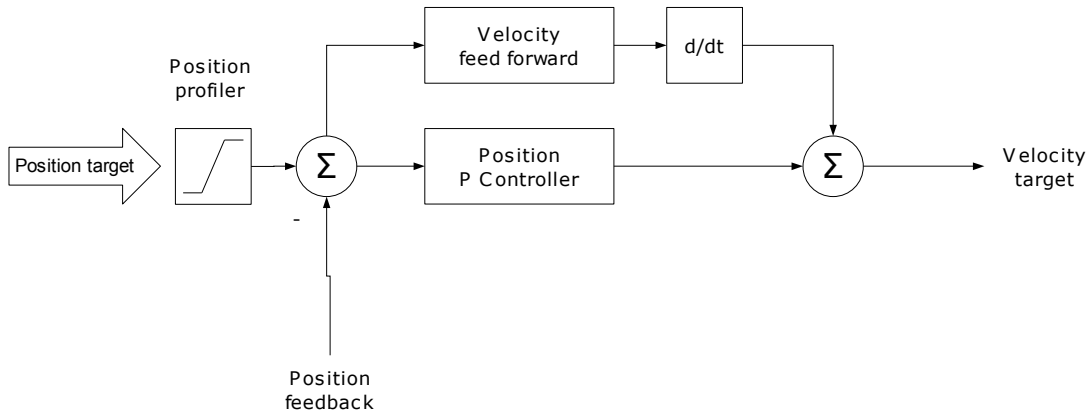

Image 5: Block diagram position controller

11.4 The PI controller

All the controller inside Basic PRO are similar, and described by this diagram:

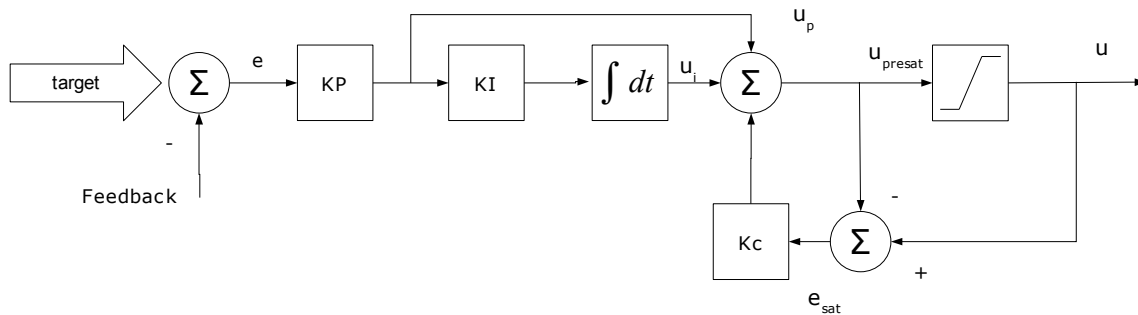

Image 6: Controller block diagram

The differential equation for PID controller with anti-windup before saturation is described in the following equation:

$$U_{presat} = U_p(t) + U_i(t) \tag{1}$$

Each term can be expressed as follows:

Proportional term: $U_p(t) = KP e(t)$ (2)

Integral term with saturation correction:

$$U_i(t) = \frac{KP}{T_i} \int_0^t \zeta d\zeta + K_c(U(t) - U_{presat}(t))$$
 (3)

where

$U(t)$ is the output of PI controller.

$U_{presat}(t)$ is the output before saturation.

$e(t)$ is the error between the reference and the feedback variables.

KP is the proportional gain of the PI controller.

T_i is $1/KP$ where KP is the integral gain.

K_c is the saturation gain of the PI controller.

Motor Power Company s.r.l.

Via Leonardo Da Vinci, 4
42024 Castelnovo Sotto Reggio Emilia - Italia
Tel. +39 0522 682710 - Fax +39 0522 683552
info@motorpowerco.it - motorpowerco.com
Cap. Soc. 50.960,00 i.v. - R.E.A. di RE 175521
Iscr.Reg.Impr. di RE n.01308390358 - N. Mecc. RE 010210
C.F. e P.IVA IT 01308390358

